

| Frame size F12 | -030 | -040 | -060 | -080 | -090 | -110 | -125 | -152 | -162 | -182 | -250 |
|---------------------------------------------------|------|------|------|-------|-------|-------|-------|-------|-------|-------|-------|
| Displacement [cm ³ /rev] | 30.0 | 40.0 | 59.8 | 80.4 | 93.0 | 110.1 | 125.0 | 149.8 | 163.1 | 179.8 | 242 |
| Operating pressure | | | | | | | | | | | |
| max intermittent ¹⁾ [bar] | 480 | 480 | 480 | 480 | 420 | 480 | 480 | 480 | 480 | 480 | 420 |
| max continuous [bar] | 420 | 420 | 420 | 420 | 350 | 420 | 420 | 420 | 420 | 420 | 350 |
| Motor operating speed [rpm] | | | | | | | | | | | |
| max intermittent ¹⁾ | 8600 | 6700 | 5800 | 5300 | 5000 | 4800 | 4600 | 4000 | 4000 | 4000 | 3000 |
| max continuous ³⁾ | 6700 | 6100 | 5300 | 4800 | 4600 | 4400 | 4200 | 3700 | 3700 | 3700 | 2700 |
| min continuous | 50 | 50 | 50 | 50 | 50 | 50 | 50 | 50 | 50 | 50 | 50 |
| Max pump selfpriming speed ²⁾ | | | | | | | | | | | |
| L or R function; max [rpm] | 3150 | 2870 | 2500 | 2300 | 2250 | 2200 | 2100 | 1700 | 1600 | 1500 | 1500 |
| Motor input flow | | | | | | | | | | | |
| max intermittent ¹⁾ [l/min] | 219 | 268 | 347 | 426 | 465 | 528 | 575 | 608 | 648 | 728 | 726 |
| max continuous [l/min] | 201 | 244 | 317 | 386 | 428 | 484 | 525 | 547 | 583 | 655 | 653 |
| Drain temperature ³⁾ , max [°C] | | | | | | | | | | | |
| min [°C] | -40 | -40 | -40 | -40 | -40 | -40 | -40 | -40 | -40 | -40 | -40 |
| Theoretical torque at 100 bar [Nm] | 47.6 | 63.5 | 94.9 | 127.6 | 147.6 | 174.8 | 198.4 | 241 | 257 | 289 | 384.1 |
| Mass moment of inertia | | | | | | | | | | | |
| (x10 ⁻³) [kg m ²] | 1.7 | 2.9 | 5 | 8.4 | 8.4 | 11.2 | 11.2 | 21 | 21 | 21 | 46 |
| Weight [kg] | 11.5 | 15.7 | 18.6 | 25.7 | 25.7 | 33 | 33 | 40 | 40 | 40 | 77 |

1) Intermittent: max 6 seconds in any one minute.

2) Selfpriming speed valid at sea level. Find more info on page 42

3) See also installation information. Page 69

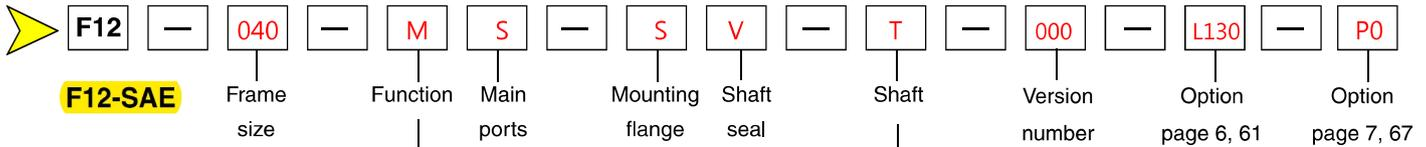

F12-SAE

| Frame size | |
|------------|-----------------------------------|
| Code | Displacem. (cm ³ /rev) |
| 030 | 30.0 |
| 040 | 40.0 |
| 060 | 59.8 |
| 080 | 80.4 |
| 090 | 93.0 |
| 110 | 110.1 |
| 125 | 125.0 |
| 152 | 149.8 |
| 162 | 163.1 |
| 182 | 179.8 |
| 250 | 242.0 |

Version number
 (assigned for special versions)

| Frame size | 30 | 40 | 60 | 80 | 90 | 110 | 125 | 152 | 162 | 182 | 250 |
|-------------|-------------------------------|-----|-----|-----|-----|-----|-----|-----|-----|-----|-----|
| Code | Function | | | | | | | | | | |
| M | Motor | x | x | x | x | x | x | x | x | x | - |
| S | Motor, high speed | (x) | (x) | (x) | - | - | - | (x) | (x) | (x) | - |
| Q | Motor | - | - | - | - | - | - | - | - | - | x |
| R | Pump, clockwise rotation | (x) | (x) | (x) | (x) | (x) | (x) | (x) | (x) | (x) | (x) |
| L | Pump, counter clockwise rot'n | (x) | (x) | (x) | (x) | (x) | (x) | (x) | (x) | (x) | (x) |

For other versions, contact Parker Hannifin

| Frame size | 30 | 40 | 60 | 80 | 90 | 110 | 125 | 152 | 162 | 182 | 250 |
|-------------|---------------------------------------|-----|-----|-----|-----|-----|-----|-----|-----|-----|-----|
| Code | Main ports | | | | | | | | | | |
| S | SAE 6000 psi flange | x | x | x | x | x | x | - | - | - | - |
| U | SAE UN threads ⁴⁾ | (x) | (x) | (x) | (x) | (x) | (x) | - | - | - | - |
| F | SAE 6000 psi flange ²⁾ | - | - | - | - | - | - | x | x | x | x |
| D | SAE 6000 psi Horizontal ²⁾ | - | - | - | - | - | - | (x) | (x) | (x) | - |
| A | SAE 6000 psi Axial ²⁾ | - | - | - | - | - | - | (x) | (x) | (x) | - |
| K | SAE 6000 psi Rear ²⁾ | - | - | - | - | - | - | (x) | (x) | (x) | - |
| M | SAE 6000 psi Side ²⁾ | - | - | - | - | - | - | (x) | (x) | (x) | - |

| Frame size | 30 | 40 | 60 | 80 | 90 | 110 | 125 | 152 | 162 | 182 | 250 |
|-------------|------------------------|----|----|----|-----|-----|-----|-----|-----|-----|-----|
| Code | Mounting flange | | | | | | | | | | |
| S | SAE 4 bolt | x | x | x | x | x | x | x | x | x | x |
| R | SAE 4 bolt | - | - | - | (x) | (x) | - | - | - | - | - |
| T | SAE 2 bolt | x | x | x | - | - | - | - | - | - | - |

- x : Available (x) : Optional - : Not available
- 1) F12-110 and -125: Accessory valve block (page 62)
 - 2) Metric threads
 - 3) Pressure setting on page 63
 - 4) Not in combination with any valve options

NOTE: All combinations are not valid, please contact Parker Hannifin

| Frame size | 30 | 40 | 60 | 80 | 90 | 110 | 125 | 152 | 162 | 182 | 250 |
|-------------|----------------------|-----|-----|-----|-----|-----|-----|-----|-----|-----|-----|
| Code | Shaft* | | | | | | | | | | |
| T | SAE key, Standard | x | x | x | x | x | x | x | x | x | x |
| R | SAE key, Optional | - | - | - | (x) | (x) | - | - | - | - | - |
| S | SAE Spline, Optional | x | x | x | x | x | x | x | x | x | x |
| F | SAE Spline, Optional | - | - | - | (x) | (x) | - | - | (x) | (x) | (x) |
| U | SAE Spline, Optional | - | - | - | (x) | (x) | - | - | - | - | - |
| K | Metric key, Standard | - | - | - | - | - | - | - | - | - | x |
| D | Spline DIN 5480 | - | - | - | - | - | - | - | - | - | (x) |
| V | Tapered shaft | (x) | (x) | (x) | - | - | (x) | (x) | - | - | - |

*See also dimensional drawings on pages 52 - 59.

| Frame size | 30 | 40 | 60 | 80 | 90 | 110 | 125 | 152 | 162 | 182 | 250 |
|-------------------|----------------------------------------------------------|-----|-----|-----|-----|-----|-----------------|-----------------|-----|-----|-----|
| Code | Option | | | | | | | | | | |
| 0000 | Standard | x | x | x | x | x | x | x | x | x | x |
| L130 | Flushing valve 1.3 mm orifice | (x) | (x) | (x) | (x) | (x) | - ¹⁾ | - ¹⁾ | - | - | - |
| MUVR | Make up/Anti cavitation valve clockwise rotation | (x) | - | - | - | - | - | - | - | - | - |
| MUVR | Make up/Anti cavitation valve counter clockwise rotation | (x) | - | - | - | - | - | - | - | - | - |
| P ₃₎ R | Pressure relief valve clockwise rotation | (x) | (x) | (x) | - | - | - | - | - | - | - |
| P ₃₎ L | Pressure relief valve counter clockwise rotation | (x) | (x) | (x) | - | - | - | - | - | - | - |

| Frame size | 30 | 40 | 60 | 80 | 90 | 110 | 125 | 152 | 162 | 182 | 250 |
|----------------|-------------------------------------------|-----|-----|-----|-----|-----|-----|-----|-----|-----|-----|
| Code | Option | | | | | | | | | | |
| 00 | Standard | - | - | - | - | - | - | - | - | - | x |
| P ₋ | Prepared for speed sensor | x | x | x | x | x | x | x | x | x | (x) |
| B ₋ | Power Boost and Prepared for speed sensor | (x) | - | - | - | - | - | - | - | - | - |
| _T | Painted Black | (x) | (x) | (x) | (x) | (x) | (x) | (x) | (x) | (x) | (x) |

| Frame size | 30 | 40 | 60 | 80 | 90 | 110 | 125 | 152 | 162 | 182 | 250 |
|-------------|--------------------------------------|----|----|----|----|-----|-----|-----|-----|-----|-----|
| Code | Shaft seal | | | | | | | | | | |
| V | FPM, high pressure, high temperature | x | x | x | x | x | x | x | x | x | x |

For other versions, contact Parker Hannifin

3

F12-30, -40, -60, -80, -90, -110 and -125
 (SAE versions with 4 bolt flange)

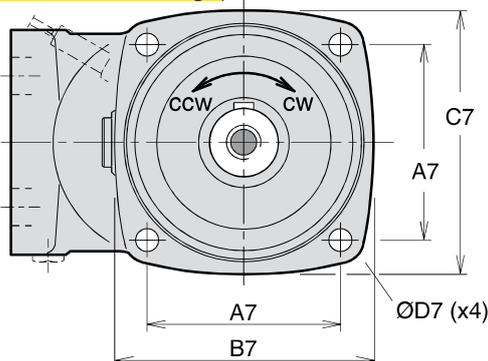

Type S (SAE 4 bolt) mounting flange

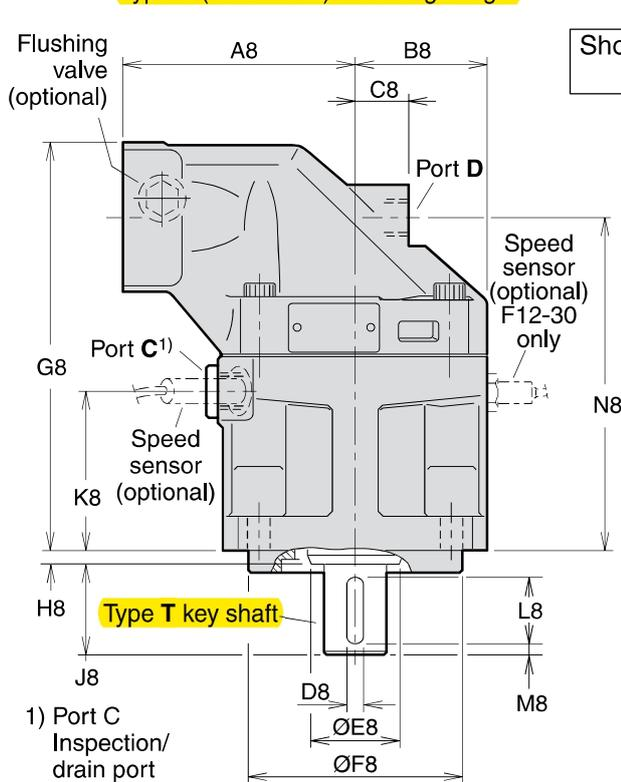
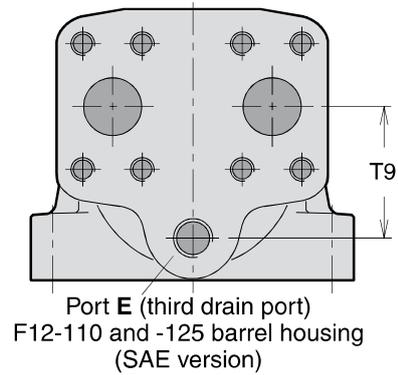

Shown: F12-80 with 4 bolt flange

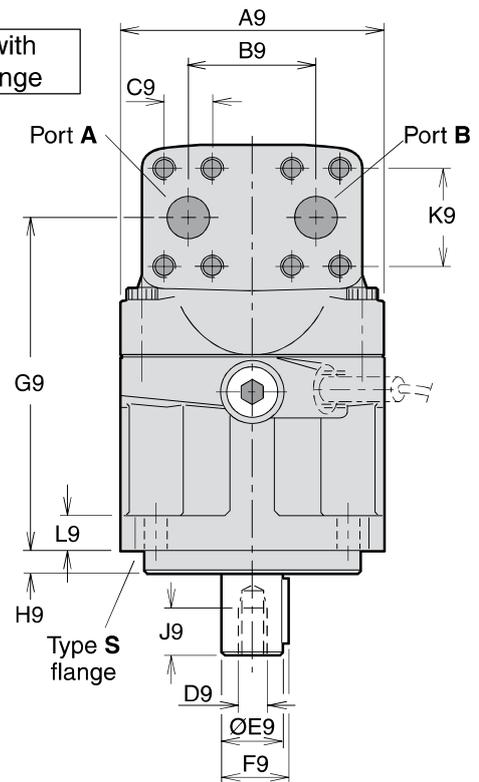

Shaft option S (U)

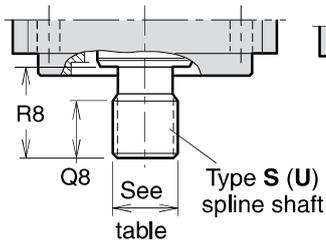

Shaft option V (F12-30)

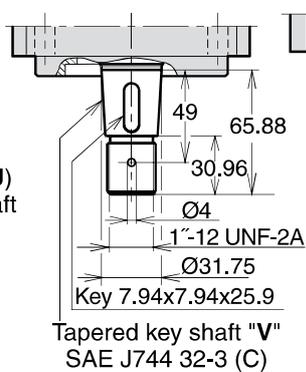

Shaft option V (F12-40)

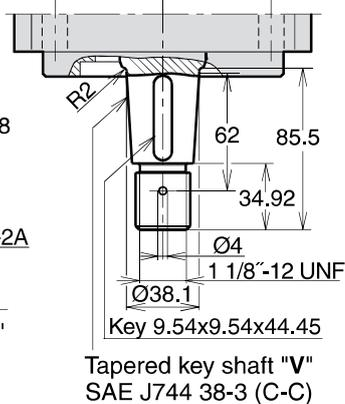

Shaft option V (F12-60)

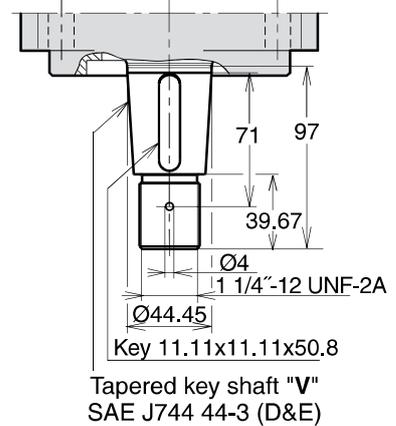

| Dim. | F12-30 | F12-40 | F12-60 | F12-80 F12-90 | F12-110 F12-125 |
|------------------|-------------------|-------------------|-------------------|-------------------|--------------------|
| A7 | 89.8 | 114.5 | 114.5 | 114.5 | 161.6 |
| B7 | 118 | 148 | 148 | 155 | 204 |
| C7 | 118 | 144 | 144 | 155 | 200 |
| D7 | 14 | 14 | 14 | 14 | 21 |
| A8 | 100 | 110 | 125 | 135 | 145 |
| B8 | 59 | 65 | 70 | 77.5 | 85 |
| C8 | 25 | 26 | 22 | 32 | 38 |
| D8 | 6.35 | 7.94 | 7.94 | 9.53 | 11.1 |
| E8 | 33 | 42 | 42 | 52 | 57.5 |
| F8 | 101.60/ 101.55 | 127.00/ 126.94 | 127.00/ 126.94 | 127.00/ 126.94 | 152.40/ 152.34 |
| G8 | 189.5 | 197 | 214 | 240 | 264 |
| H8 | 8 | 8 | 8 | 8 | 8 |
| J8 | 38 | 48 | 48 | 54 | 67 |
| K8 | 72 | 76 | 79 | 95 | 99 |
| L8 | 31.8 | 38.1 | 38.1 | 44.5 | 54.1 |
| M8 | 2.5 | 4 | 4 | 4 | 7.5 |
| N8 | 153.5 | 161 | 178.3 | 197.1 | 212 |
| Q8 ¹⁾ | 26 | 27 | 27 | 29 | 39 |
| Q8 ²⁾ | - | - | - | 23 | - |
| R8 ¹⁾ | 33 | 48 | 48 | 54 | 66.7 |
| R8 ²⁾ | - | - | - | 48 | - |
| A9 | 122 | 134 | 144 | 155 | 170 |
| B9 | 66 | 66 | 66 | 75 | 83 |
| C9 | 23.8 | 23.8 | 23.8 | 27.8 | 31.8 |
| D9* | 5/16"-24 | 3/8"-24 | 3/8"-24 | 1/2"-20 | 5/8"-18 |
| E9 | 25.40/ 25.35 | 31.75/ 31.70 | 31.75/ 31.70 | 38.10/ 38.5 | 44.45/ 44.40 |
| F9 | 28.2 | 35.3 | 35.3 | 42.3 | 49.4 |
| G9 | 153.8 | 161 | 178.3 | 197.1 | 212 |
| H9 | 9.7 | 12.7 | 12.7 | 12.7 | 12.7 |
| J9 | 16 | 19 | 19 | 26 | 32 |
| K9 | 50.8 | 50.8 | 50.8 | 57.2 | 66.7 |
| L9 | 18 | 20 | 20 | 20 | 22 |
| T9 | - | - | - | - | 68 |

- * UNF-2B thread
 1) Spline shaft type **S**
 2) Spline shaft type **U**
 3) Max operating pressure 350 bar

| Main ports A and B, type U (optional) | |
|----------------------------------------------|-------------------------------------|
| F12-30 | 1 1/16" - 12 UN ³⁾ |
| F12-40 | 1 5/16" - 12 UN ³⁾ |
| F12-60 | 1 5/16" - 12 UN³⁾ |
| F12-80 | 1 5/16" - 12 UN ³⁾ |
| F12-90 | 1 5/16" - 12 UN ³⁾ |
| F12-110 | 1 5/8" - 12 UN ³⁾ |
| F12-125 | 1 5/8" - 12 UN ³⁾ |

| Ports | F12-30 | F12-40 | F12-60 | F12-80 F12-90 | F12-110 F12-125 |
|-----------------|----------------|----------------|----------------|------------------|--------------------|
| A, B size | 3/4" | 3/4" | 3/4" | 1" | 1 1/4" |
| Screw thread**) | 3/8"-16 x22 | 3/8"-16 x20 | 3/8"-16 x22 | 7/16"-14 x27 | 1/2"-13 x25 |
| C thread | 7/8"-14 | 7/8"-14 | 7/8"-14 | 7/8"-14 | 1 1/16"-12 |
| D thread | 3/4"-16 | 3/4"-16 | 7/8"-14 | 7/8"-14 | 1 1/16"-12 |
| E thread | - | - | - | - | 1 1/16"-12 |

A, B: ISO 6162 C, D, E: O-ring boss (SAE J514)
 **) UN thread x depth in mm.

Mounting flange (SAE J744)

| | S (standard) | R (optional) |
|--------|-----------------|-----------------|
| F12-30 | SAE 'B', 4 bolt | - |
| -40 | SAE 'C', 4 bolt | - |
| -60 | SAE 'C', 4 bolt | - |
| -80 | SAE 'C', 4 bolt | SAE 'D', 4 bolt |
| -90 | SAE 'C', 4 bolt | SAE 'D', 4 bolt |
| -110 | SAE 'D', 4 bolt | - |
| -125 | SAE 'D', 4 bolt | - |

Spline shaft (SAE J498b, class 1, flat root, side fit)

| | S (standard) | U (opt.) | F (optional) |
|--------|----------------------------|----------------------------------------|-------------------------|
| F12-30 | SAE 'B' 13T, 16/32 DP | - | - |
| -40 | SAE 'C' 14T, 12/24 DP | - | - |
| -60 | SAE 'C' 14T, 12/24 DP | - | - |
| -80 | SAE 'C-C' 17T, 12/24 DP | SAE 'C' 14T, 12/24 DP ³⁾ | SAE 'D' 13T, 8/16 DP |
| -90 | SAE 'C-C' 17T, 12/24 DP | SAE 'C' 14T, 12/24 DP ³⁾ | SAE 'D' 13T, 8/16 DP |
| -110 | SAE 'D' 13T, 8/16 DP | - | - |
| -125 | SAE 'D' 13T, 8/16 DP | - | - |

Key shaft (SAE J744)

| F12 | T (standard) | R (optional) | V (optional) |
|------|--------------------------------|-------------------------------|--------------|
| -30 | SAE 'B-B' (Ø25.4 mm/1") | - | 32-3 |
| -40 | SAE 'C' (Ø31.75 mm/1 1/4") | - | 38-3 |
| -60 | SAE 'C' (Ø31.75 mm/1 1/4") | - | 44-3 |
| -80 | SAE 'C-C' (Ø38.1 mm/1 1/2") | SAE 'D' (Ø44.45 mm/1 3/4") | - |
| -90 | SAE 'C-C' (Ø38.1 mm/1 1/2") | SAE 'D' (Ø44.45 mm/1 3/4") | - |
| -110 | SAE 'D' (Ø44.45 mm/1 3/4") | - | 44-3 |
| -125 | SAE 'D' (Ø44.45 mm/1 3/4") | - | 44-3 |

Integrated flushing valve (F12-30, -40, -60, -80, -90)

General information

The integrated flushing valve supplies the motor with a cooling flow through the case which may be required when operating at high speeds and power levels.

In a closed loop hydrostatic transmission the flushing valve secures that cool fluid from the charge circuit is constantly added to the main circuit.

The flushing valve consists of a 'three-position', three-way spool valve which connects the low pressure side of the main hydraulic circuit with the motor case. The valve opens at a pressure differential between port A and port B of approximately 14 bar.

In order to limit the flow, a nozzle with a orifice is available from Parker Hannifin. The diagram to the right shows flow versus differential pressure.

For general advise when flushing might be needed, see page 67.

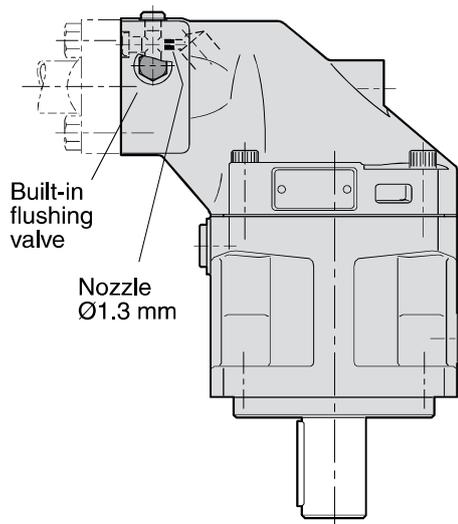

4

Integrated flushing valve (F12-30, -40, -60, -80, -90) **Nozzle Ø1.3 mm**

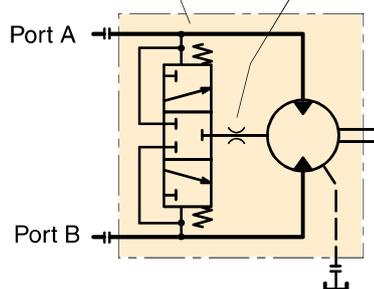

Hydraulic schematic.

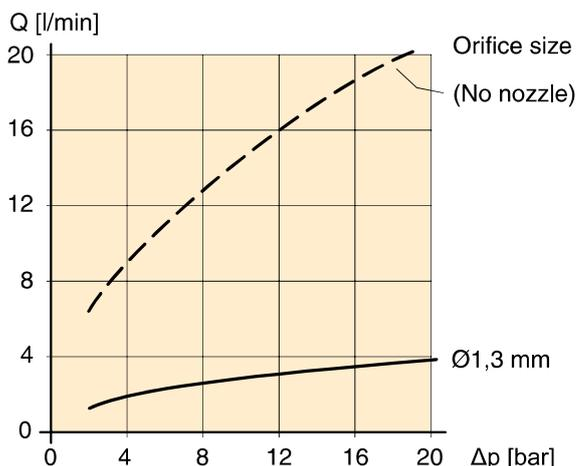

Flow versus pressure differential (port A or B to tank).

Ordering code

F12 - **080** - **MF** - **IV** - **K** - **000** - **L130** - **P0**

Standard F12 ordering code
 (for F12-30, -40, -60, -80, -90)

| Code | Nozzle designation |
|-------|--------------------|
| L 130 | 1,3 mm |

NOTE: FV13 flushing valve block for F12-110 shown on next page.