

Technical  
Information

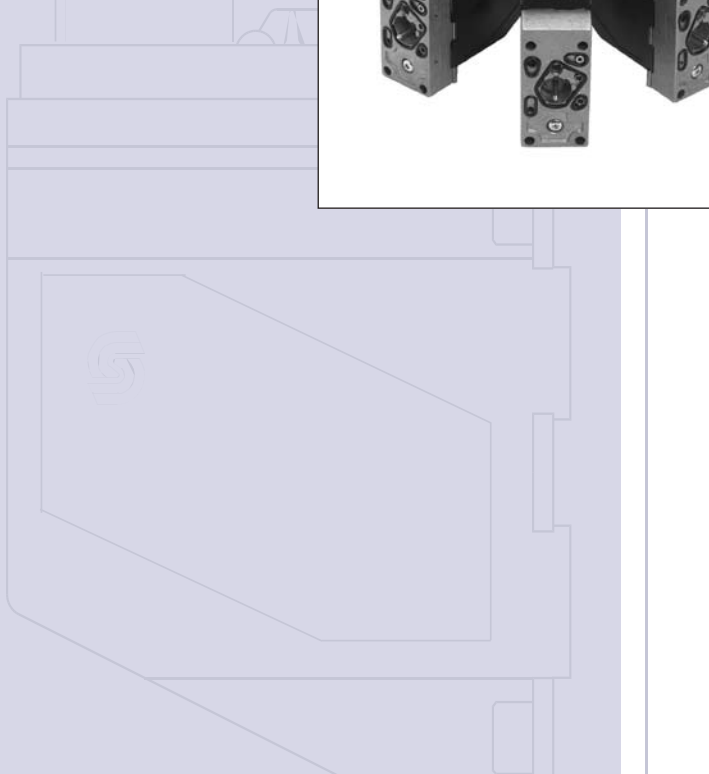
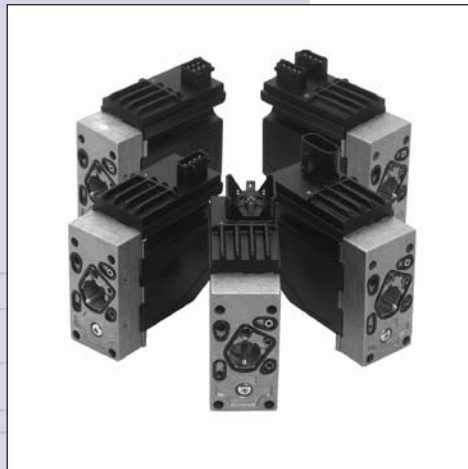
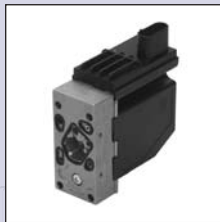
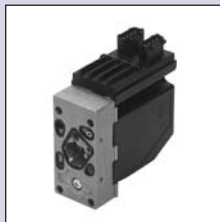
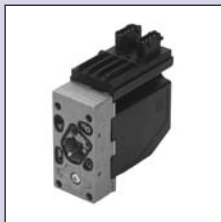

### Revision History

Date	Page	Changed	Revision
May 2008	9	tabel and text	DB
Jan 2009	16	UDC - UDC2 changed places	DD
Feb 2009	27	Material number changed	DE
May 2010	Many	Handles on various drawings changed, Japan location	EA

### Contents

Contents - Introduction .....	2
Function.....	3
Electrical Actuation.....	4
Technical Data .....	8
Fault Monitoring System .....	12
Dimensions.....	14
Connection and Activation.....	16
Activation Characteristic.....	20
Direction Indicator .....	23
Electrical Systems .....	24
System Control Logic .....	25
Code Numbers .....	29

### Introduction

Product developments based on Sauer-Danfoss' activities in research and development, and design of new components is determined by market and customer requirements, thus contributing to maintaining and extending our leading market position in the field of electro hydraulically operated hydraulic valves.

The technology used in PVE series 4 is based on proven electronic development principles known from e.g. the automobile industry - together with our long experience within electrical activation of hydraulic valves for the mobile market. These factors will not only maintain the high level of quality and reliability experienced with PVE series 2 and 3, but will also give specification improvements for the PVE modules – e.g. the environmental protection.

This catalogue will give you an introduction to the different PVE modules, their functions and technical data.

© 2008 Sauer-Danfoss. All rights reserved. Printed in Europe  
 Sauer-Danfoss accepts no responsibility for possible errors in catalogs, brochures and other printed material. Sauer-Danfoss reserves the right to alter its products without prior notice. This also applies to products already ordered provided that such alterations aren't in conflict with agreed specifications. All trademarks in this material are properties of their respective owners. Sauer-Danfoss and the Sauer-Danfoss logotype are trademarks of the Sauer-Danfoss Group.

Front cover illustrations: F300700, F3007012, F300702, F300704  
 drawing: 157-506

**Function**

The philosophy of Sauer-Danfoss electro hydraulic actuation, type PVE, is integration of electronics, sensors and actuators into a single unit that interfaces directly to the proportional valve body.

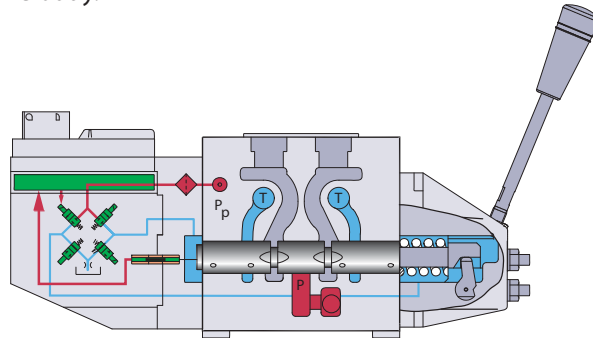

V310134.A

**Closed loop control**

All the proportional actuators feature an integrated feedback transducer that measures spool movement in relation to the input signal, and by means of a solenoid valve bridge, controls the direction, velocity and position of the main spool of the valve. The integrated electronics compensate for flow forces on the spool, internal leakage, changes in oil viscosity, pilot pressure, etc. This results in lower hysteresis and better resolution. Furthermore the electronics enable built in safety like fault monitoring, directional indication and LED light indication.

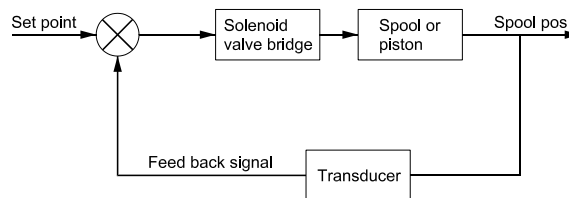

157-503.10

**Principle**

In principle the input signal (set-point signal) determines the level of pilot pressure which moves the main spool. The position of the main spool is sensed in the LVDT transducer which generates an electric feed-back signal registered by the electronics. The variation between the set-point signal and feed-back signal actuates the solenoid valves. The solenoid valves are actuated so that hydraulic pilot pressure drives the main spool into the correct position.

**Inductive transducer, LVDT**

(Linear Variable Differential Transformer). When the main spool is moved, a voltage is induced proportional to the spool position. The use of LVDT gives contact-free monitoring of the main spool position. This means an extra-long working life and no limitation as regards the type of hydraulic fluid used. In addition, LVDT gives a precise position signal of high resolution.

**Integrated pulse width modulation**

Positioning of the main spool in PVEA/PVEH/PVES is based on the pulse width modulation principle. As soon as the main spool reaches the required position, modulation stops and the spool is locked in position.

**ON/Off Actuation**

With electrical ON/OFF actuation the main spool is moved from neutral to maximum stroke when power is connected.

**PVEO, ON/OFF**

Main features of PVEO:

- Compact
- Robust operation
- With Hirschmann, Deutsch or AMP connector
- Low electrical power
- As option with directional indicator (DI)

**PVEO-R, ON/OFF with hydraulic ramp**

Like PVEO, but for applications where longer reaction time is needed.

With electrical proportional actuation the main spool position is adjusted so that it corresponds to an electrical signal – e.g. from a remote control unit.

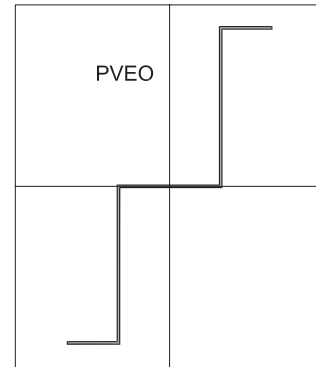

157-513.10

**Proportional Actuation**

**PVEA, proportional fine**

PVEA versions are recommended where among the requirements are fault monitoring, low hysteresis, high resolution but where the reaction time is not critical.

Main features of PVEA:

- Inductive transducer
- Integrated pulse width modulation
- Low hysteresis
- AMP or Deutsch connector
- As option with directional indicator (DI)
- Fault monitoring with transistor output for signal source.
- Low electrical power
- No set-up procedure

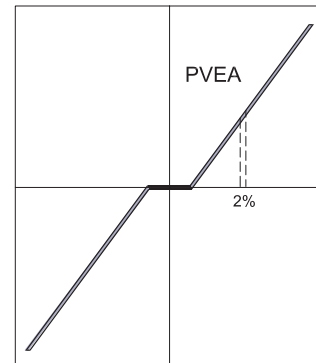

157-510.10

**PVEH, proportional high**

Performance like PVEA but with fast reaction time.

Main features of PVEH:

- Inductive transducer
- Integrated pulse width modulation
- Low hysteresis
- Fast reaction time
- Hirschmann, Deutsch or AMP connector
- As option with directional indicator (DI)
- Fault monitoring with transistor output for signal source
- Low electrical power
- No set-up procedure

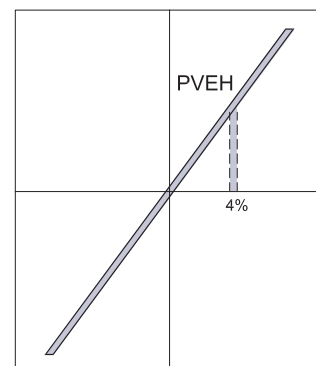

157-511.10

**Proportional Actuation (continued)**

**PVES, proportional super**  
 PVES versions are recommended for control systems requiring very low hysteresis to obtain a high resolution. For other technical data: see PVEH

- Hirschmann, Deutsch or AMP connector

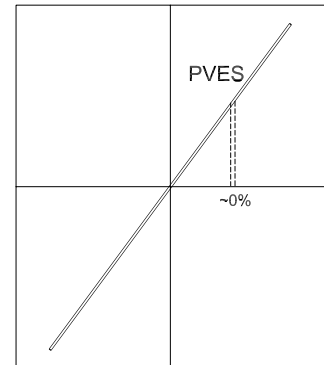

157-775.10

**Hydraulic Principles**

**PVEO**

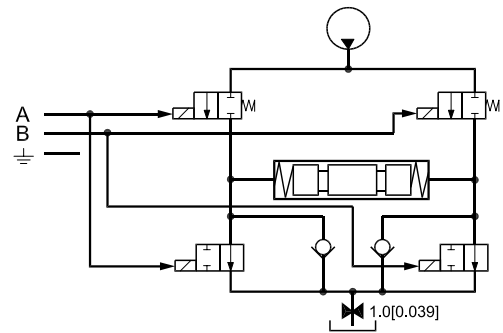

157-470.10

**PVEO-R**

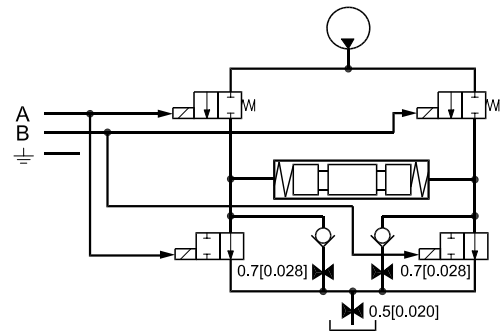

157-469.10

**PVEO-DI**

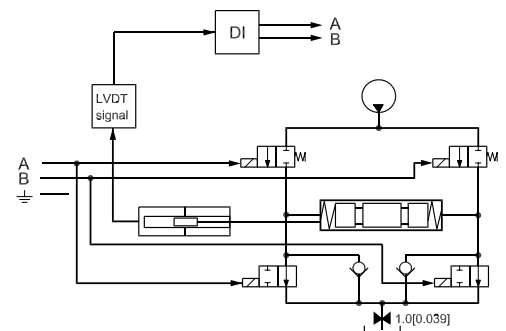

157-776.10

**Hydraulic Principles  
 (continued)**

**PVEA**

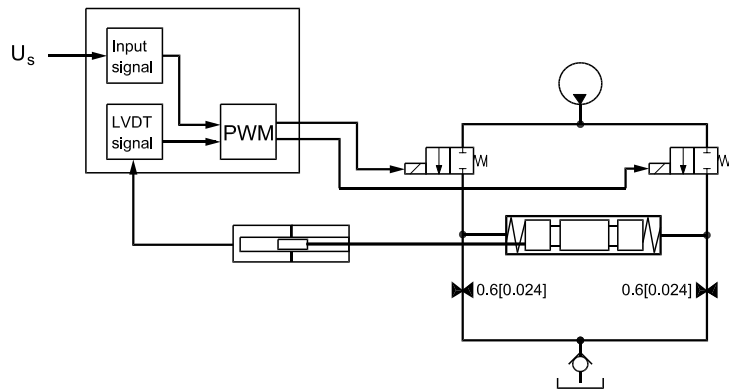

157-337.10

**PVEA-DI**

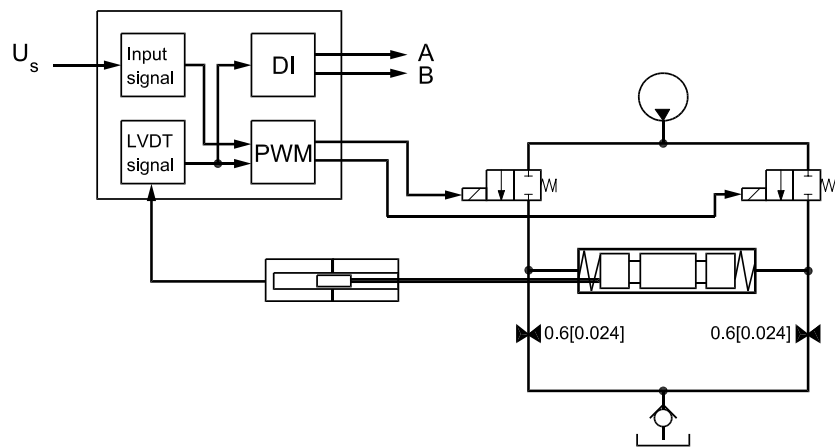

157-338.10

**PVEH/PVES**

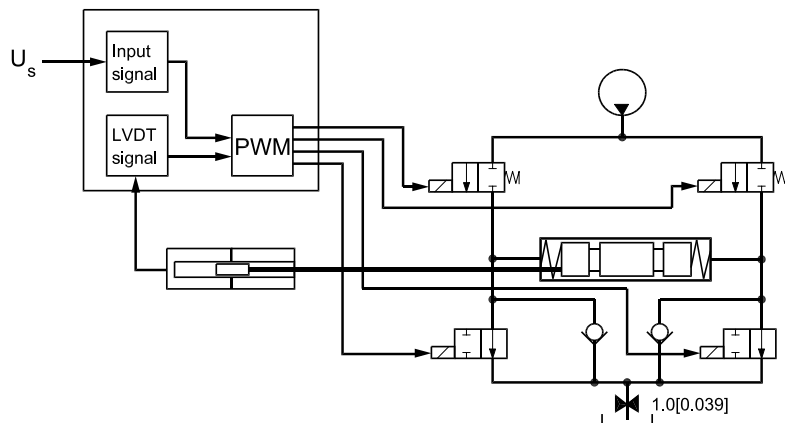

157-360.10

**Hydraulic Principles**  
 (continued)

**PVEH-DI**

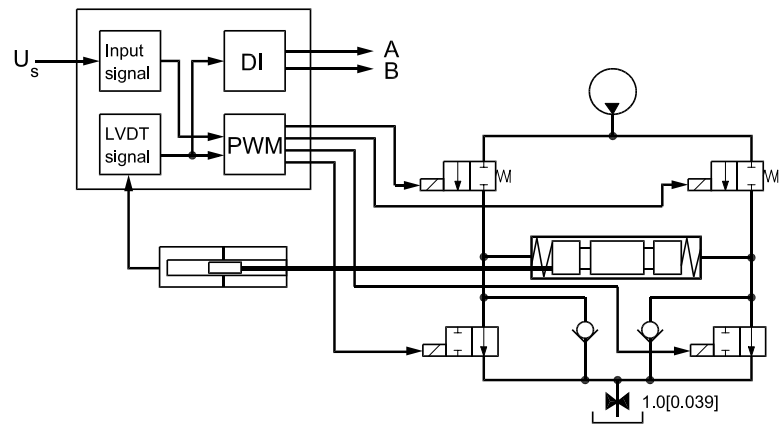

157-515.10

**Technical Data**

The following technical data are from typical test results. For the hydraulic system a mineral based hydraulic oil with a viscosity of 21 mm<sup>2</sup>/s [102 SUS] and a temperature of 50° C [122° F] were used.

*PVEO*

		PVEO	
Supply voltage U <sub>DC</sub>	rated	12 V DC	24 V DC
	range	11 V to 15 V	22 V to 30 V
	max. ripple	5%	

*Reaction time PVEO (minus PVG 120)*

Supply voltage	Function		PVEO ON/OFF s	PVEO-R ON/OFF s
Disconnected by means of neutral switch	Reaction time from neutral position to max. spool travel	max.	0.235	0.410
		rated	0.180	0.350
		min.	0.120	0.250
Disconnected by means of neutral switch	Reaction time from max. spool travel to neutral position	max.	0.175	0.330
		rated	0.090	0.270
		min.	0.065	0.250

*PVEA, PVEH and PVES*

		PVEA, PVEH and PVES	
Supply voltage U <sub>DC</sub>	rated	11 V to 32 V	
	range	11 V to 32 V	
	max. ripple	5%	
Current consumption at rated voltage	PVEH/PVES (PVEA)	0.57 (0.33) A @ 12 V	0.3 (0.17) A @ 24 V
Signal voltage	neutral	0.5 x U <sub>DC</sub>	
	A-port ↔ B-port	0.25 • U <sub>DC</sub> to 0.75 • U <sub>DC</sub>	
Signal current at rated voltage		0.25 mA to 0.70 mA	
Input impedance in relation to 0.5 • U <sub>DC</sub>		12 KΩ	
Power consumption	PVEH/PVES (PVEA)	7 (3.5) W	



**Technical Data  
(continued)**

Function	PVEP
Supply voltage Vbat range	11 - 32 V
Supply voltage Vbat max. ripple	5%
Supply voltage Vbat over voltage (max. 5 min)	36 V
PWM control range (duty cycle)	10 - 80%
PWM float position control	PWM_A = PWM_B = 90%
PWM frequency	100 - 1000 Hz
PWM input voltage swing	0 - Vbat
PWM Trigger point	70 % of Vbat
Input impedance (standard pull down)	5 k Ohm
Input capacitor	---
Power consumption	7 W
Error voltage: Fault	Vbat
Error voltage: No Fault	< 2 V

All connector terminals are short-circuit protected, and protected against reverse connection ( and their combinations).

Connecting error pins from two or more PVE's will cause the surveillance system to malfunction

**⚠ WARNING**

It's up to the customer to decide on the required degree of safety for the system.

*Reaction time PVEA, PVEH and PVES (minus PVG 120)*

Supply voltage	Function		PVEA Prop. fine s	PVEH Prop. high s	PVES Prop. super s	PVEP PWM Ctrl s
Disconnected by means of neutral switch	Reaction time from neutral position to max. spool travel	max.	0.500	0.230	0.230	0.230
		rated	0.320	0.150	0.150	0.150
		min.	0.250	0.120	0.120	0.120
Disconnected by means of neutral switch	Reaction time from max. spool travel to neutral position	max.	0.550	0.175	0.175	0.175
		rated	0.400	0.090	0.090	0.090
		min.	0.300	0.065	0.065	0.065
Constant voltage	Reaction time from neutral position to max. spool travel	max.	0.500	0.200	0.200	0.200
		rated	0.320	0.120	0.120	0.120
		min.	0.250	0.050	0.050	0.050
Constant voltage	Reaction time from max. spool travel to neutral position	max.	0.250	0.100	0.100	0.100
		rated	0.200	0.090	0.090	0.090
		min.	0.150	0.065	0.065	0.065
Hysteresis <sup>1)</sup>		rated	2%	4%	~ 0%	5%

<sup>1)</sup> Hysteresis is indicated at rated voltage and f=0.02 Hz for one cycle (one cycle = neutral -> full A -> full B -> neutral).

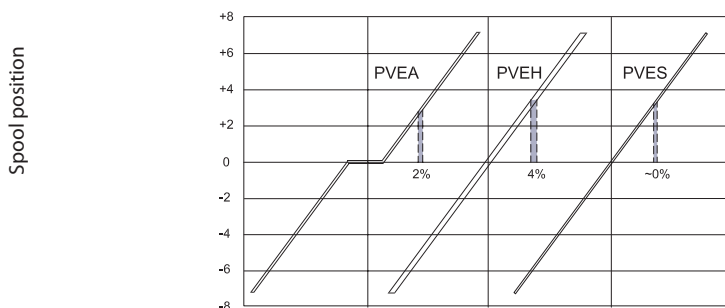

157-777.10

**Technical Data  
 (continued)**

*Oil consumption PVEO*

Supply voltage	Function	PVEO ON/OFF
Without voltage	Pilot oil flow per PVE neutral*	0 l/min [0 US gal/min]
With voltage	Pilot oil flow per PVE locked*	0.1 l/min [0.026 US gal/min]
	continuous actuations*	0.7 l/min [0.185 US gal/min]

\* 12 bar and 21 mm<sup>2</sup>/s [174 psi and 101.9]

*Oil consumption PVEA, PVEH and PVES*

Supply voltage	Function	PVEA Prop. fine	PVEH Prop. high	PVES Prop. super
Without voltage	Pilot oil flow per PVE neutral*	0 l/min [0 US gal/min]	0 l/min [0 US gal/min]	0.3 l/min [0.106 US gal/min]
With voltage	Pilot oil flow per PVE locked*	0.4 l/min [0.106 US gal/min]	0.1 l/min [0.026 US gal/min]	0.1 l/min [0.026 US gal/min]
	continuous actuations*	1.0 l/min [0.264 US gal/min]	0.7 l/min [0.185 US gal/min]	0.8 l/min [0.211 US gal/min]

\* 12 bar and 21 mm<sup>2</sup>/s [174 psi and 101.9]

*Oil viscosity*

Oil viscosity	range	12 - 75 mm <sup>2</sup> /s [65 - 347 SUS]
	min.	4 mm <sup>2</sup> /s [39 SUS]
	max.	460 mm <sup>2</sup> /s [2128 SUS]

Note: Max. start up viscosity 2500 mm<sup>2</sup>/s

*Oil temperature*

Oil -temperature	Rec. range	30 - 60°C [86 -140°F]
	min.	-30°C [-22°F]
	max.	90°C [194°F]

*Filtering*

Filtering in the hydraulic system	Max. allowed degree of contamination (ISO 4406, 1999 version): 23/19/16
-----------------------------------	---

*Ambient temperature*

Ambient temperatur range Rec.	-30° → +60°C [-22° → +140°F]
-------------------------------	------------------------------

**Technical Data  
 (continued)**

*Pilot pressure*

Pilot pressure (relative to T pressure)	nom.	13.5 bar [196 psi]
	min.	10 bar [145 psi]
	max.	15 bar [217 psi]

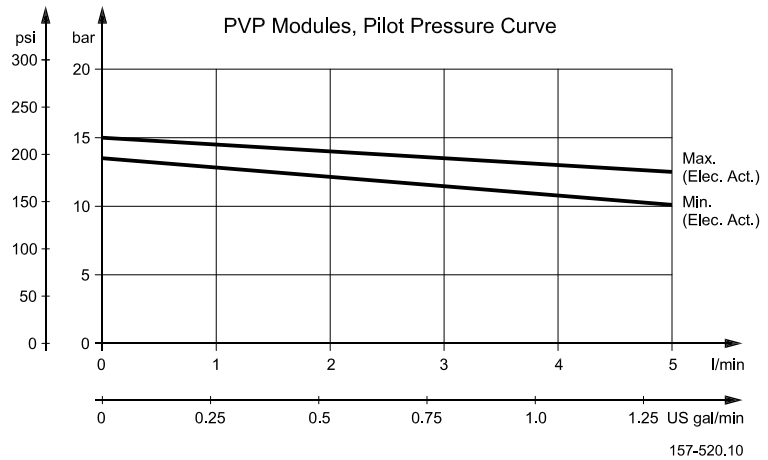

*Enclosure and connector*

Version with Hirschmann connector	
Grade of enclosure *	IP 65

Version with AMP JPT connector	
Grade of enclosure *	IP 66

\* According to the international standard IEC 529  
 NB: In particularly exposed applications, protection in the form of screening is recommended.

*Enclosure and connector*

Version with Deutsch connector	
Grade of enclosure *	IP 65 / IP 69 K

## The Fault Monitoring System

A fault monitoring system is provided in all PVEA, PVEH and PVES modules. The system is available in two versions:

- The active fault monitoring type, which provides a warning signal, deactivates the solenoid valves and drives the spool in neutral.
- The passive fault monitoring type, which provides a warning signal only.

Both active and passive fault monitoring systems are triggered by three main events:

### 1. Input signal monitoring

- The input signal voltage is continuously monitored. The permissible range is between 15% and 85% of the supply voltage. Outside this range the section will switch into an active error state.

### 2. Transducer supervision

- If one of the wires to the LVDT sensor is broken or short-circuited, the section will switch into an active error state.

### 3. Supervision of the closed loop

- The actual position must always correspond to the demanded position (input signal). If the actual spool position is further than the demanded spool position (>12%, PVEA: >25%), the system detects an error and will switch into an active error state. On the other hand, a situation where the actual position is closer to neutral than that demanded will not cause an error state. This situation is considered "in control".
- When an active error state occurs, the fault monitoring logic will be triggered:

#### Active fault monitoring

- A delay of 500 ms (PVEA: 750 ms) before anything happens.
- The solenoid valve bridge will be disabled and all solenoid valves will be released.
- An alarm signal is sent out through the appropriate pin connection.
- This state is memorized and continues until the system is actively reset (by turning off the supply voltage).

#### Passive fault monitoring

- A delay of 250 ms (PVEA: 750 ms) before anything happens.
- The solenoid valve bridge will not be disabled but still control the main spool position.
- An alarm signal is sent out through the appropriate pin connection.
- This state is not memorized. When the erroneous state disappears, the alarm signal will turn to passive again. However, the signal will always be active for a minimum of 100 ms when triggered.

To prevent the electronics from going into an undefined state, a general supervision of the power supply and the internal clock frequency is made. This function applies to PVEA, PVEH and PVES - and will not activate fault monitoring:

#### 1. High supply voltage

- The solenoid valves are disabled when the supply voltage exceeds 36 V, and the main spool will return/stay in neutral.

#### 2. Low supply voltage:

- The solenoid valves are disabled when the supply voltage falls below 8.5 V, and the main spool will return/stay in neutral.

**The Fault Monitoring System (continued)**

**3. Internal clock**

- The solenoid valves are disabled when the internal clock frequency fails, and the main spool will return/stay in neutral.

**▲ WARNING**

It's up to the customer to decide on the required degree of safety for the system (see page 21).

**Fault Monitoring Overview**

Type	Fault monitoring	Delay before error out	Error mode	Error output status	Fault output on PVE <sup>1)</sup>	LED light	Memory (reset needed)
PVEO	No fault monitoring	-	-	-	-	-	-
PVEA PVEH PVES	Active	500 ms (PVEA: 750ms)	No fault	Low	< 2 V	Green	-
			Input signal faults	High	~U <sub>DC</sub>	Flashing red	Yes
			Transducer (LVDT)			Constant red	
	Close loop fault						
	Passive	250 ms (PVEA: 750ms)	No fault	Low	< 2 V	Green	-
			Input signal faults	High	~U <sub>DC</sub>	Flashing red	No
Transducer (LVDT)			Constant red				
Close loop fault							

<sup>1)</sup> Measured between fault output pin and ground

**General Dimensions**

**PVE with Hirschmann connector**

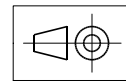
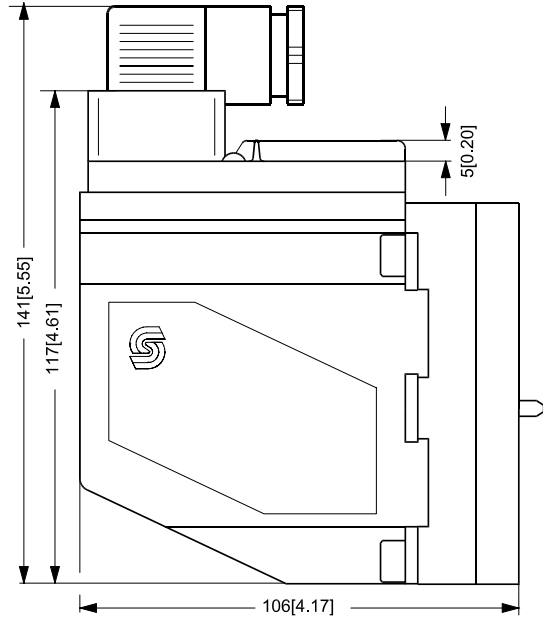
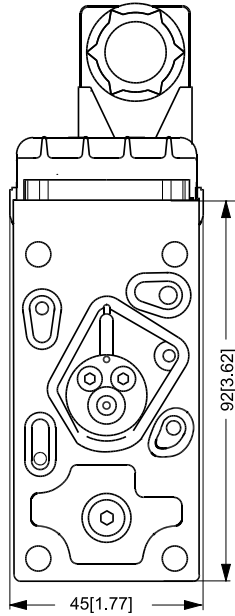

157-517.14

**PVE with AMP connector**

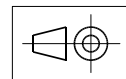
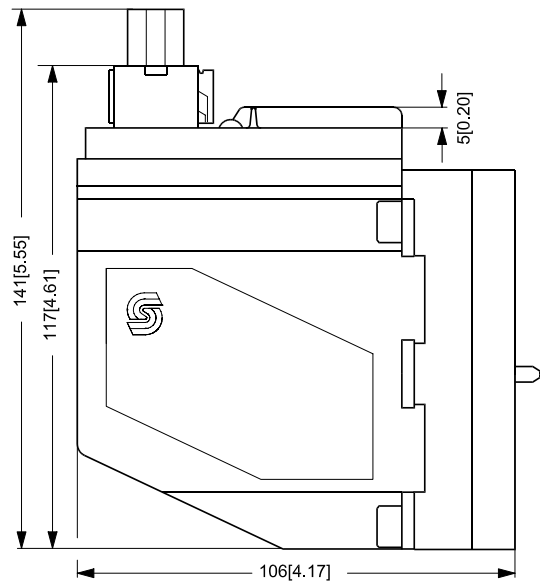
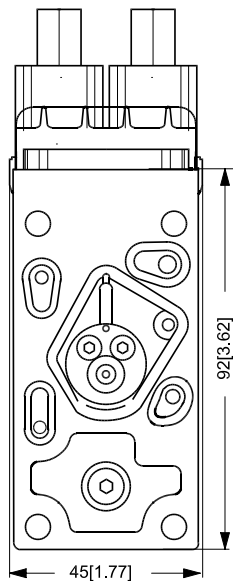

157-394.14

**General Dimensions**  
 (continued)

**PVE with deutsch connector**

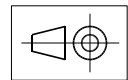
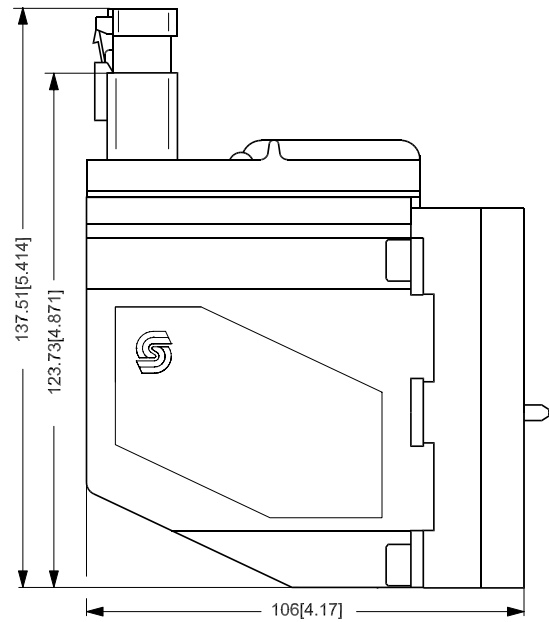
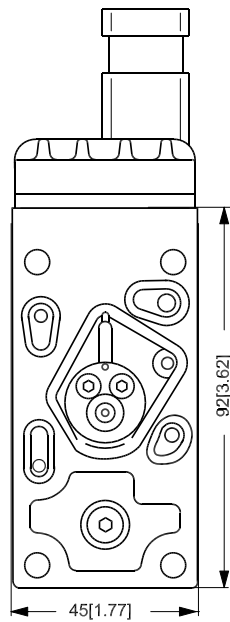

157-722.10

**AMP-Version ON/OFF**

Function	Signal voltage (A or B)	
	A (pin 1)	B (pin 2)
Neutral	0	0
Q: P -> A	$U_{DC}$	0
Q: P -> B	0	$U_{DC}$

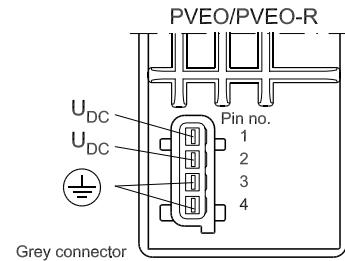

157-498.12

On DI versions two  $U_{DC}$  connections ( $U_{DC}$  and  $U_{DC2}$ ) are necessary.

- $U_{DC2}$  will supply the electronics
- $U_{DC}$  will supply the solenoid valves

two ground pins (pin 3) are internally connected. With advantages two separate power supplies can be used, see also system safety page 25.

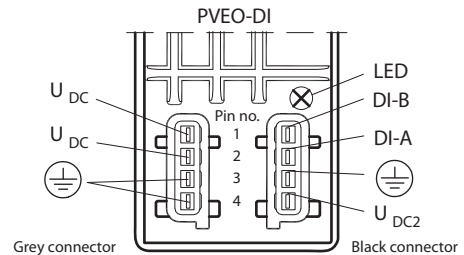

P301 104

**AMP-Version Proportional**

Function	Signal voltage ( $U_s$ )
Neutral	$U_s$ (pin 1) = $0.5 \cdot U_{DC}$
Q: P -> A	$U_s$ (pin 1) = $(0.5 \rightarrow 0.25) \cdot U_{DC}$
Q: P -> B	$U_s$ (pin 1) = $(0.5 \rightarrow 0.75) \cdot U_{DC}$

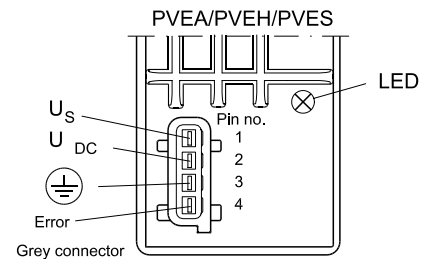

157-500.10

On DI versions two  $U_{DC}$  connections ( $U_{DC}$  and  $U_{DC2}$ ) are necessary.

- $U_{DC}$  will supply the electronics
- $U_{DC2}$  will supply the solenoid valves

two ground pins (pin 3) are internally connected. With advantages two separate power supplies can be used, see also system safety page 25.

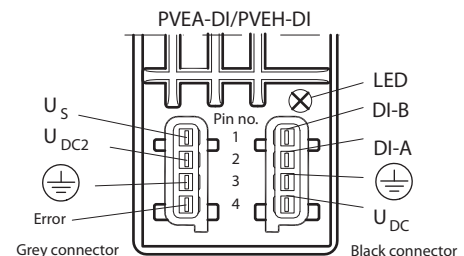

P301 106

**Hirschmann-Version ON/OFF**

Function	Signal voltage (A or B)	
	A (pin 1)	B (pin 2)
Neutral	0	0
Q: P -> A	$U_{DC}$	0
Q: P -> B	0	$U_{DC}$

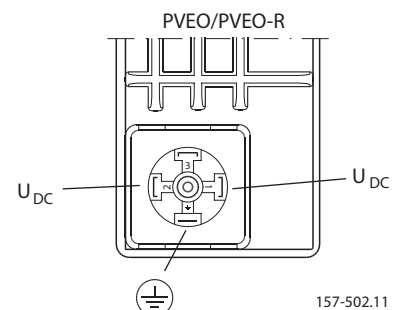

157-502.11



**Hirschmann-Version  
 Proportional**

Function	Signal voltage ( $U_s$ )
Neutral	$U_s (\text{pin 2}) = 0.5 \cdot U_{DC}$
Q: P -> A	$U_s (\text{pin 2}) = (0.5 \rightarrow 0.25) \cdot U_{DC}$
Q: P -> B	$U_s (\text{pin 2}) = (0.5 \rightarrow 0.75) \cdot U_{DC}$

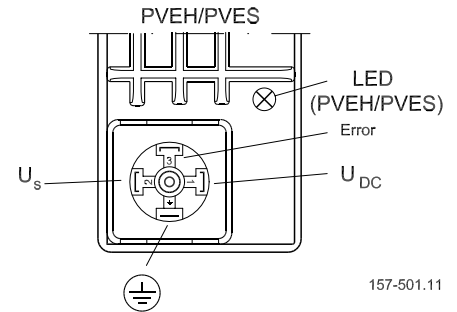

**Deutsch-Version  
 ON/OFF**

Function	Signal voltage (A or B)	
	A (pin 1)	B (pin 4)
Neutral	0	0
Q: P -> A	$U_{DC}$	0
Q: P -> B	0	$U_{DC}$

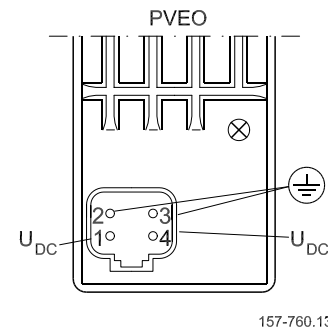

**Deutsch-Version  
 Proportional**

Function	Signal voltage ( $U_s$ )
Neutral	$U_s (\text{pin 1}) = 0.5 \cdot U_{DC}$
Q: P -> A	$U_s (\text{pin 1}) = (0.5 \rightarrow 0.25) \cdot U_{DC}$
Q: P -> B	$U_s (\text{pin 1}) = (0.5 \rightarrow 0.75) \cdot U_{DC}$

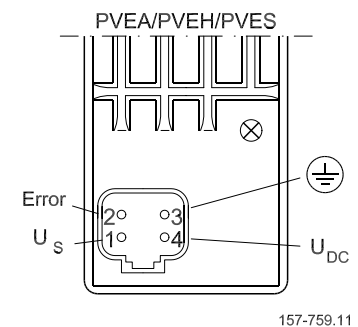

On DI versions two  $U_{DC}$  connections ( $U_{DC}$  and  $U_{DC2}$ ) are necessary.

- $U_{DC}$  will supply the electronics
  - $U_{DC2}$  will supply the solenoid valves
- two ground pins (pin 3) are internally connected.

With advantages two separate power supplies can be used, see also system safety page 25.

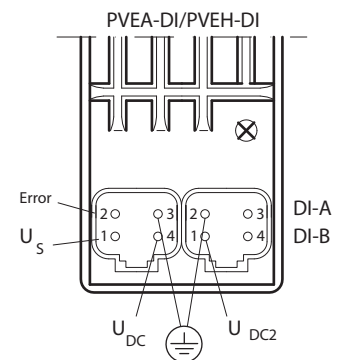

Technical Information  
Connection and Activation

AMP-Version  
Float Option for PVBZ

Function	$U_s$ (pin 1)	Float (pin 5)
Neutral	$0.5 \times U_{DC}$	0
Q: P -> A	$(0.5 \rightarrow 0.25) \times U_{DC}$	0
Q: P -> B	$(0.5 \rightarrow 0.75) \times U_{DC}$	0
Float	None or any voltages $\leq U_{DC}$	$U_{DC}$

For further information, see 520L0567

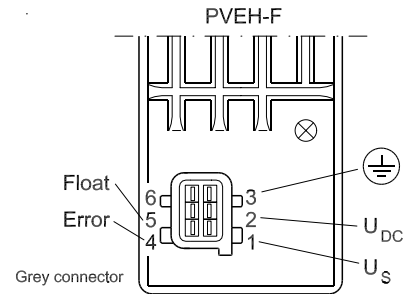

157-529.12

AMP-Version  
CAN-bus

Function	CAN-message
Neutral	Port flow: 0 Valve state: 0
Q: P -> A	Port flow: 1 - 100% Valve state: 1
Q: P -> B	Port flow: 1 - 100% Valve state: 2

For further information, see 520L0665

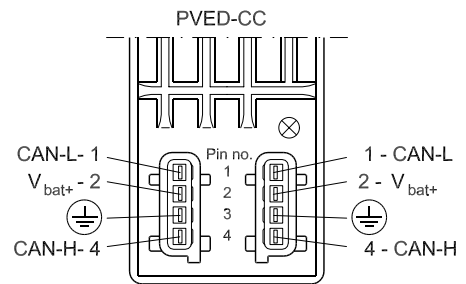

157-574.12

Deutsch-Version  
Float Option for PVBZ

Function	$U_s$ (pin 1)	Float (pin 5)
Neutral	$0.5 \times U_{DC}$	0
Q: P -> A	$(0.5 \rightarrow 0.25) \times U_{DC}$	0
Q: P -> B	$(0.5 \rightarrow 0.75) \times U_{DC}$	0
Float	None or any voltages $\leq U_{DC}$	$U_{DC}$

For further information, see 520L0567

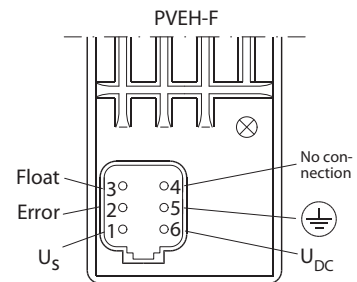

P301 029

Deutsch-Version  
CAN-bus

Function	CAN-message
Neutral	Port flow: 0 Valve state: 0
Q: P -> A	Port flow: 1 - 100% Valve state: 2
Q: P -> B	Port flow: 1 - 100% Valve state: 1

For further information, see 520L0665

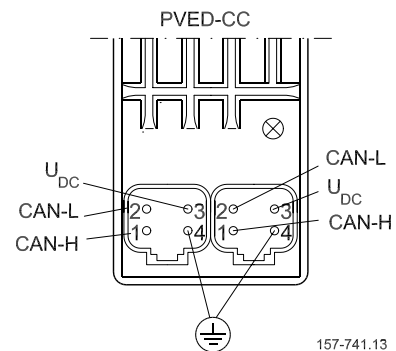

157-741.13

**Deutsch-Version**  
**PVEP**

Duty cycle A-signal (pin 1)	Duty cycle B-signal (pin 3)	Function
0%	0%	Neutral
0 - 10%	0%	
0%	0 - 10%	
≥10%	≥10%	Fault (error)
0%	10 - 80%	P - B
10 - 80%	0	P - A

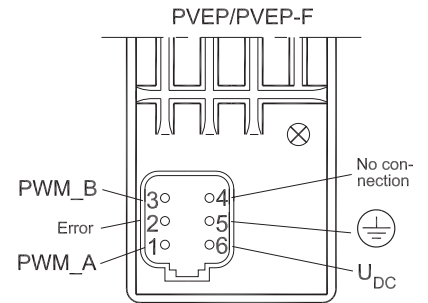

157-728.13

**Float Option for PVEP - F**

Duty cycle A-signal (pin 1)	Duty cycle B-signal (pin 3)	Function
0%	0%	Neutral
0 - 10%	0%	
0%	0 - 10%	
≥10%	≥10%	Fault (error)
0%	10 → 80%	P - B 0 → 5.5 mm
10 → 80%	0%	P - A 0 → 5.5 mm
90%	90%	Float A-port (8 mm)
≥90%	0%	Fault (error)
0%	≥90%	Fault (error)

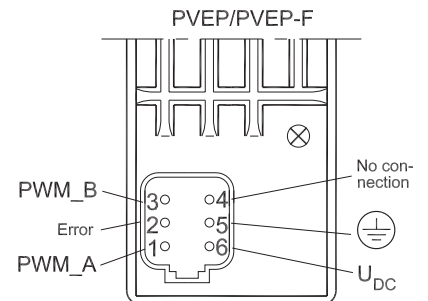

157-728.13

For further information, see 520L0921

**Standard Main Spools**

**Characteristics; oil flow, spool travel and voltage**

The spools have 7 mm spool travel in direction A and 7 mm travel in direction B:

- 7 mm [0.27 in] spool displacement in direction A gives max. oil flow to port A
- 7 mm [0.27 in] spool displacement in direction B gives max. oil flow to port B

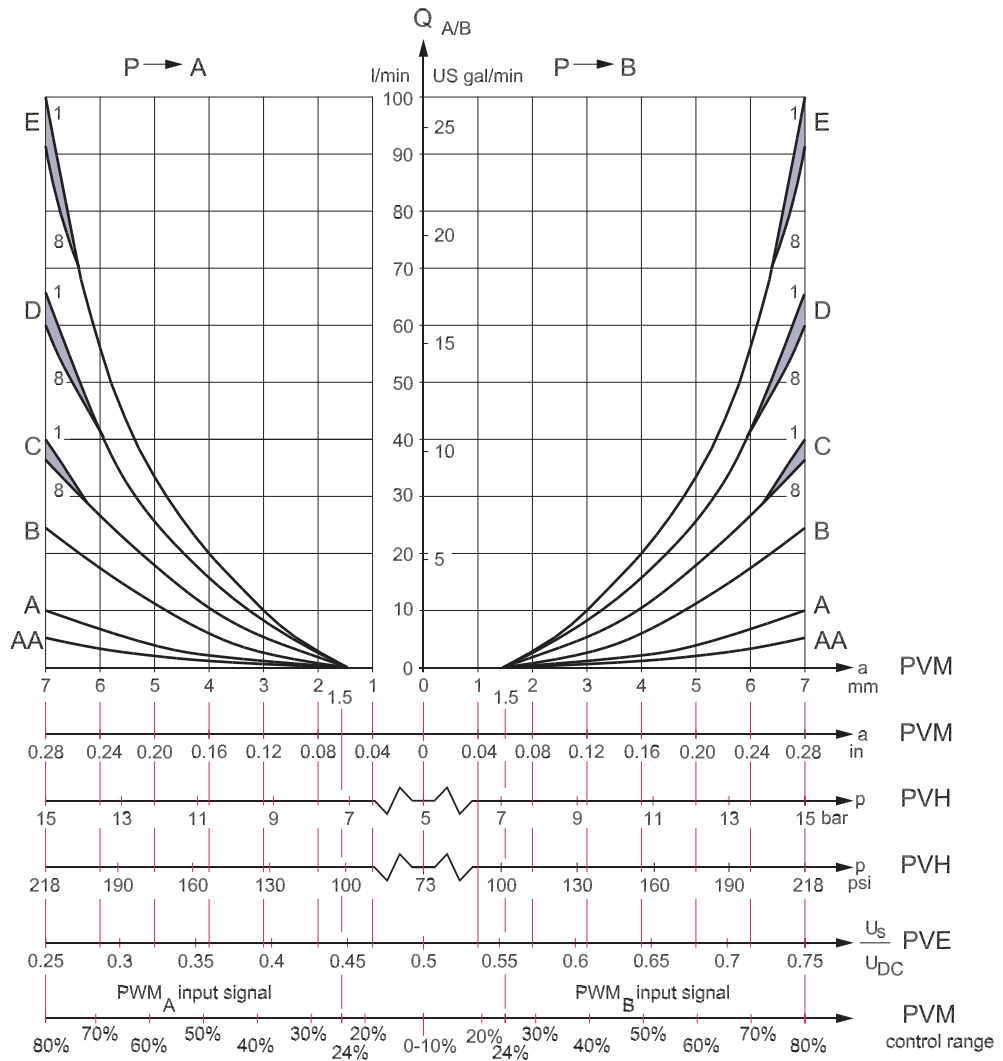

157-61.12

**Float Spools, PVBS**

**Characteristics; oil flow, spool travel and voltage**

The spools have 4,8 mm spool travel in direction A and 8 mm travel in direction B:

- 4.8 mm [0.19 in] spool displacement in direction A gives max. oil flow to port A
- 4.8 mm [0.19 in] spool displacement in direction B gives max. oil flow to port B
- 8 mm [0.32 in] spool displacement in direction B gives completely open float position A/B → T.

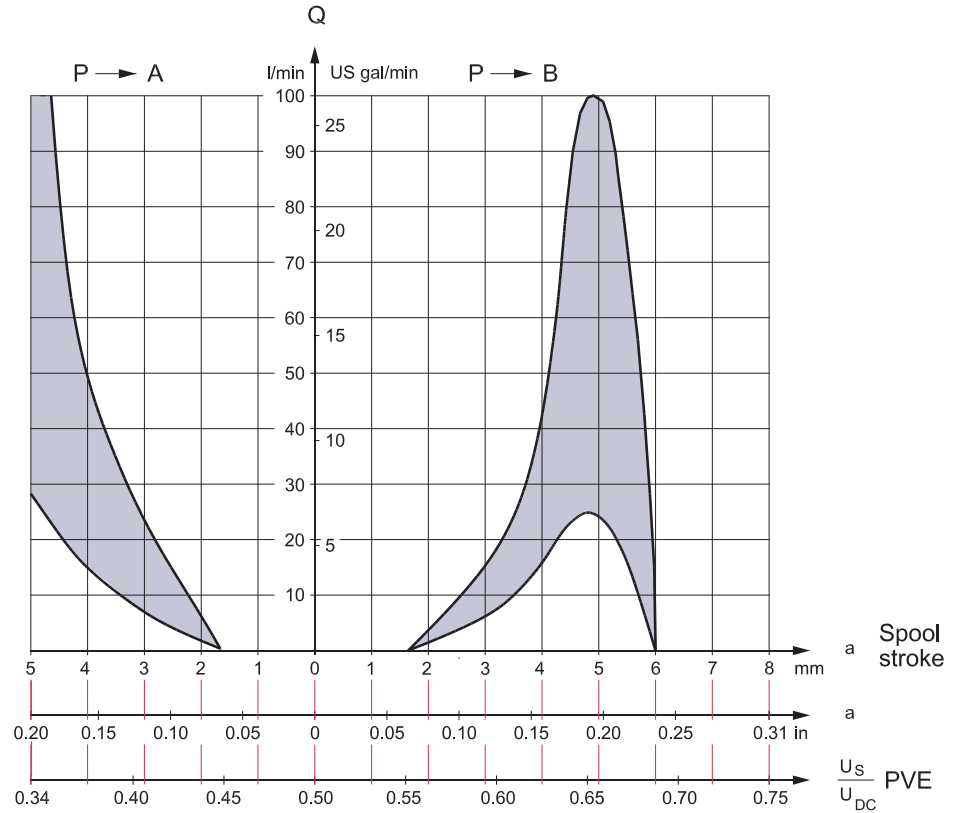

157-507.11

**Float Spools, PVBZ**

**Characteristics; oil flow, spool travel and voltage**

The spools have 5.5 mm spool travel in direction A and 8 mm travel in direction B:

- 5.5 mm [0.19 in] spool displacement in direction A gives max. oil flow to port A
- 5.5 mm [0.19 in] spool displacement in direction B gives max. oil flow to port B
- 8 mm [0.32 in] spool displacement in direction A gives completely open float position A/B → T.

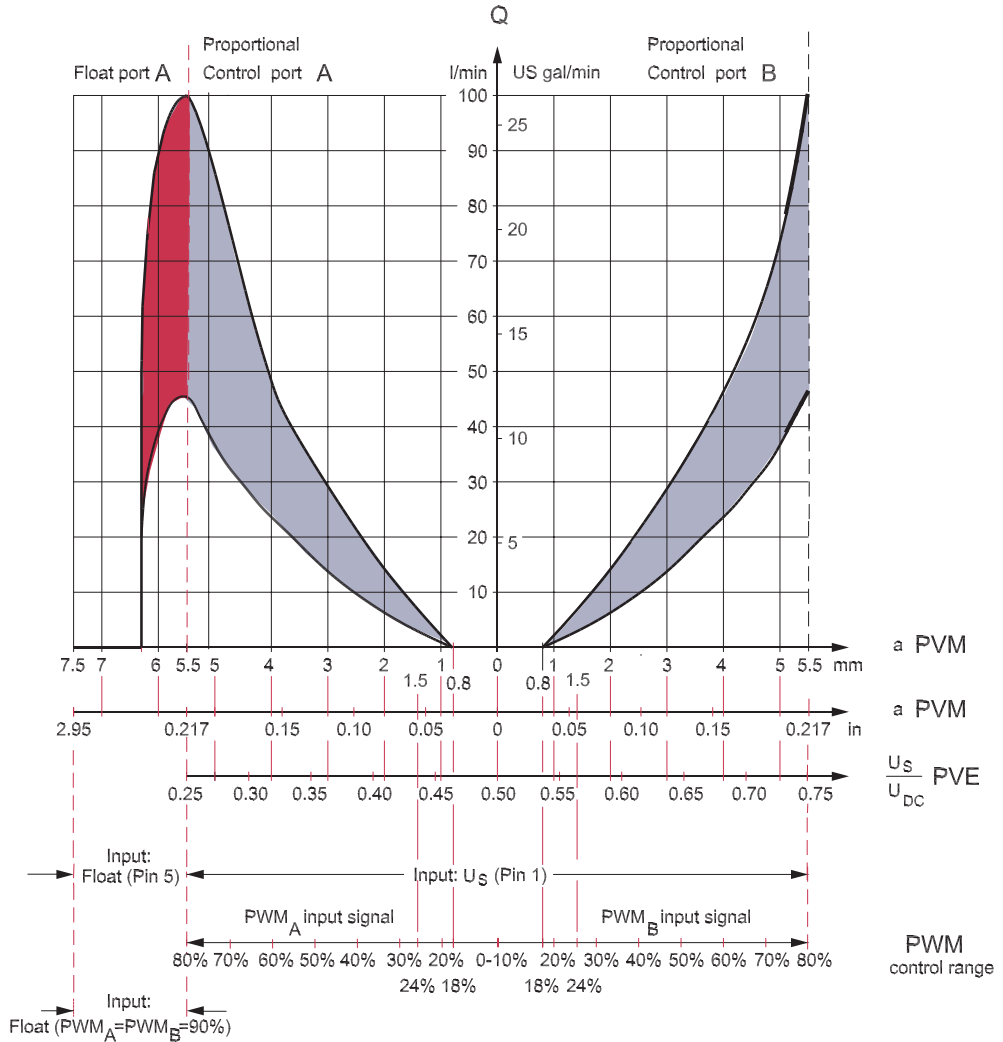

157-532.12

**Direction Indicator**

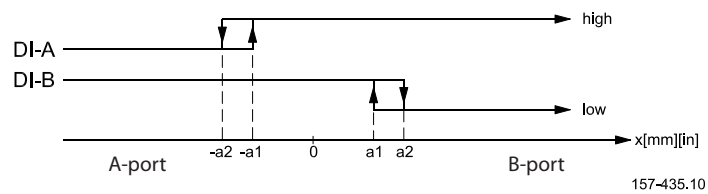

	A-port	B-port
Direction signals "a1", "a2"	-0.8 ± 0.4 mm [0.031 ± 0.015 in]	0.8 ± 0.4 mm [0.031 ± 0.015 in]
Max. load of "Dir_A", "Dir_B"	50 mA	
Voltage "High" value with load of "Dir_A" or "Dir_B" = 20 mA	Minimum. U <sub>DC</sub> - 1.5 V	
Voltage "High" value with load of "Dir_A" or "Dir_B" = 50 mA	Minimum. U <sub>DC</sub> - 2.0 V	
Voltage "Low" value	Maximum: 0.2 V	

As shown in the figure, both "Dir\_A" and "Dir\_B" signals are "High" when the spool is in Neutral position. When the spool is moving in the A direction, the "Dir\_A" signal goes "Low" and the "Dir\_B" signal stays "High". The reverse is true when the spool is moved in the B direction.

**Examples of Use**

Signal leads must not act as supply leads at the same time unless the distance between the actuator module PVE and terminal board is less than 3 m [3.3 yards] and the lead cross-section is min. 0.75 mm<sup>2</sup> [AWG 18].

**25 Pin SUB-D connector**  
 with M3 screws (MIL-DTL-24308)

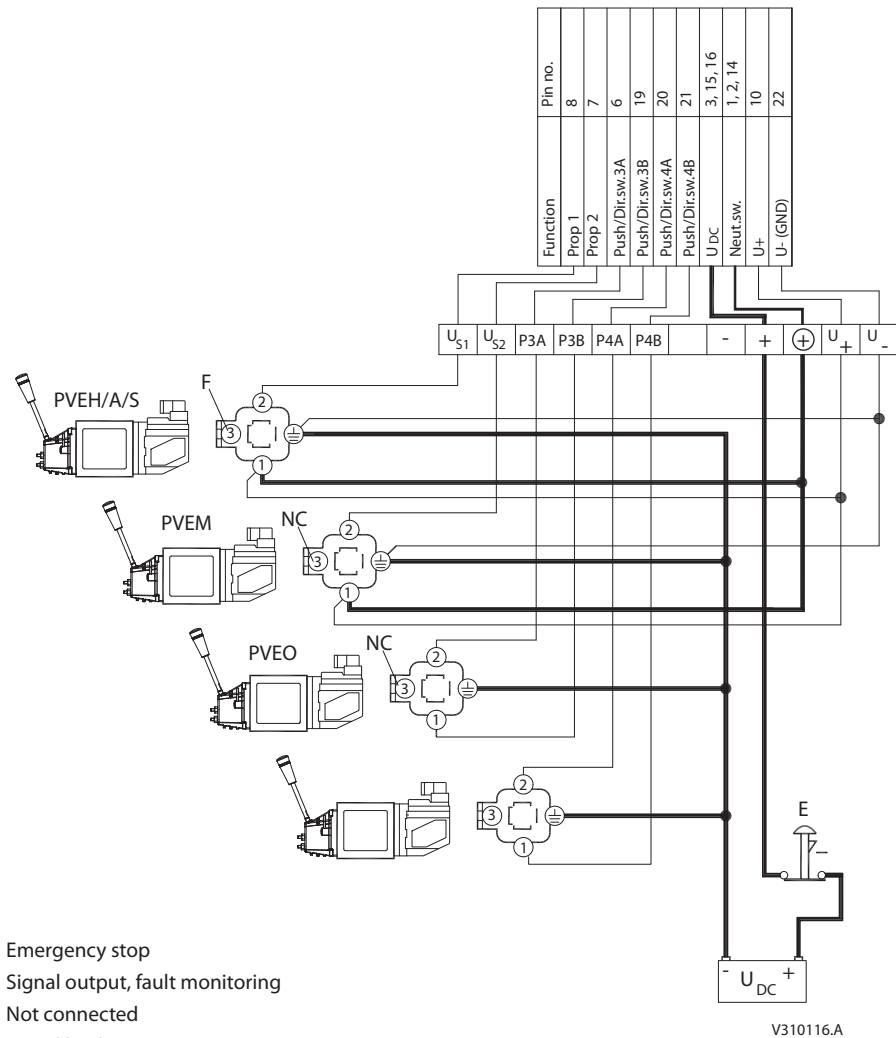
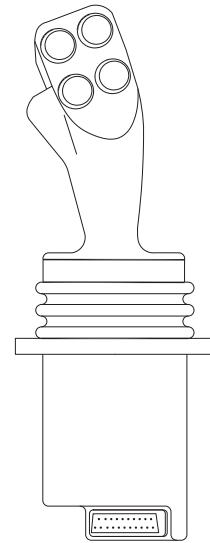
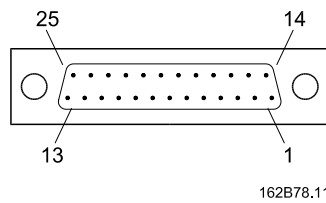

- E : Emergency stop
- F : Signal output, fault monitoring
- NC : Not connected
- : Signal leads
- : Supply leads

V310116.A



**▲ WARNING**

All marks and all types of directional control valves – inclusive proportional valves – can fail and cause serious damage. It is therefore important to analyse all aspects of the application.

Because the proportional valves are used in many different operation conditions and applications, the manufacturer of the application is alone responsible for making the final selection of the products – and assuring that all performance, safety and warning requirements of the application are met.

The process of choosing the control system – and safety level – could e.g. be governed by EN 954-1 (Safety related parts of control system).

**Building in Safety**

Example 1:

Proposal for a system with continuous monitoring and detection:

- PVE with DI function (Direction Indicator) and active fault monitoring
- 2 separate power supplies – one for the PVE function and one for the DI function
  - make it possible to interrupt the PVE function without losing the DI function. E.g. the machine operator can activate the emergency stop device and stop the function
  - but still have the DI signal active for the overall safety system (e.g. a controller).
- The overall safety system (e.g. a controller) uses the fault indication from the DI function or the fault monitoring to interrupt the valve function (e.g. dump the pump flow).

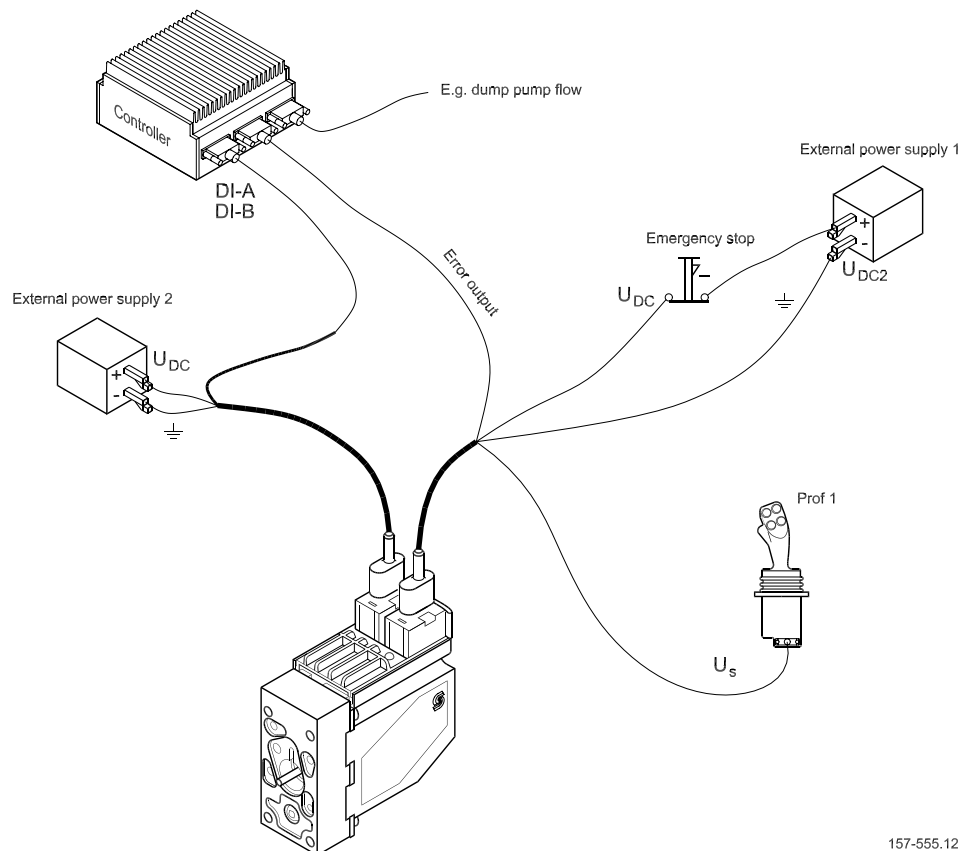

157-555.12

**Example (continued)**

Example 2:

Proposal for a system with fault monitoring and detection:

- PVE with active fault monitoring
- The fault monitoring can be used to interrupt the valve function (e.g. dump the pump flow).
- Activation of the emergency stop device will stop the function – but also disconnect the fault monitoring system.

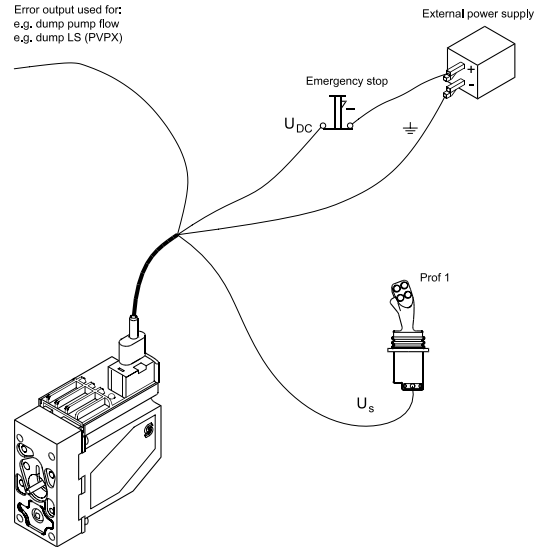

157-557,11

Example 3:

Simple system without fault monitoring and detection:

- PVEO
- Activation of the emergency stop device will stop the function

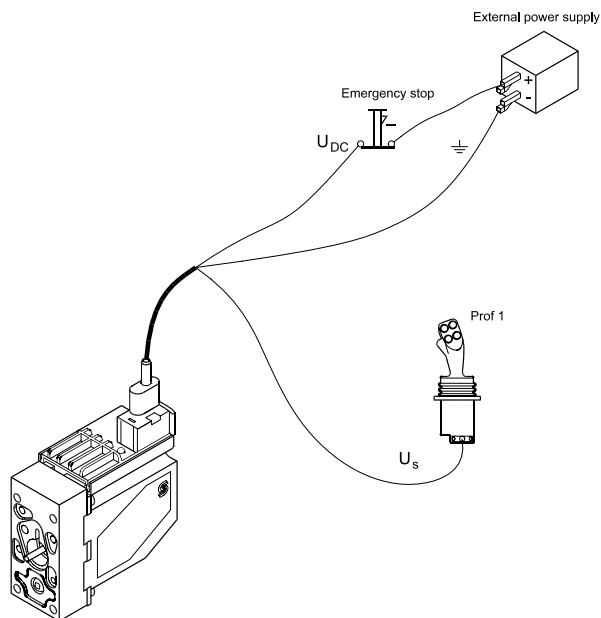

157-556,11



PVE Series 4 for PVG 32, PVG 100 and PVG 120  
Technical Information  
Notes

Notes



PVE Series 4 for PVG 32, PVG 100 and PVG 120  
Technical Information  
Notes

Notes

**Code Numbers for  
 Use on PVG 32  
 157B....**

*PVE for PVG 32 and PVG 100*

PVEO, ON/OFF actuation Code no. 157B....		Hirschmann connector 12 V 24 V		AMP connector 12 V 24 V		Deutsch connector 12 V 24 V	
PVEO	ON/OFF	4216, 4266*	4228, 4268*	4901	4902, 4272*	4291	4292
	ON/OFF with ramp	4217	4229	4903	4904	Not available	Not available
	PVEO-DI	Not available	Not available	4905	4906	Not available	Not available

PVEA/PVEH/PVES, proportional actuation Code no. 157B....		Hirschmann connector 11 - 32 V	AMP connector 11 - 32 V	Deutsch connector 11 - 32 V
PVEA	Standard, active fault monitoring	Not available	4734	4792
	Standard, passive fault monitoring	Not available	4735, 4775*	Not available
PVEA-DI	Standard, active fault monitoring	Not available	4736	4796
	Standard, passive fault monitoring	Not available	4737	Not available
PVEH	Standard, active fault monitoring	4032	4034, 4074*	4092
	Standard, passive fault monitoring	4033, 4073*	4035, 4075*	4093
	Float -> B, active fault monitoring	4332	Not available	4392
PVEH-DI	Standard, active fault monitoring	Not available	4036	4096
	Standard, passive fault monitoring	Not available	4037	Not available
PVES	0% hysteresis, active fault monitoring	4832	4834	4892
	0% hysteresis, passive fault monitoring	4833	4835, 4865*	Not available

\* Anodized versions

PVED-CC, proportional actuation 157B....		AMP connector 11 V 32 V	Deutsch connector 11 V 32 V
PVED-CC	ISOBUS	4943	4944

PVEH-F, proportional actuation 157B....		AMP connector 11 V 32 V	Deutsch connector 11 V 32 V
PVEH-F	Float -> A Active fault monitoring	4338	Not available

PVEP, proportional actuation		Deutsch connector 11 V 32 V
PVEP	Active fault monitoring	11034832
PVEP-F	Float -> A Active fault monitoring	157B4753

*PVE for PVG 120*

PVEO/PVEH electrical actuation Code no. 155G....		Hirschmann connector	AMP connector
PVEO	ON/OFF, 12 V	4272	4282
	ON/OFF, 24 V	4274	4284
PVEH	Standard, active fault monitoring	4092	4094
	Standard, passive fault monitoring	4093	4095



PVE Series 4 for PVG 32, PVG 100 and PVG 120  
Technical Information  
Notes

Notes



## Our Products

Open circuit axial piston pumps  
Gear pumps and motors  
Fan drive systems  
Closed circuit axial piston pumps and motors  
Bent axis motors  
Hydrostatic transmissions  
Transit mixer drives  
Hydrostatic transaxles  
Electrohydraulics  
Integrated systems  
Microcontrollers and software  
PLUS+1™ GUIDE  
Displays  
Joysticks and control handles  
Sensors  
Orbital motors  
Inverters  
Electrohydraulic power steering  
Hydraulic power steering  
Hydraulic integrated circuits (HIC)  
Cartridge valves  
Directional spool valves  
Proportional valves

## Sauer-Danfoss Mobile Power and Control Systems – Market Leaders Worldwide

Sauer-Danfoss is a comprehensive supplier providing complete systems to the global mobile market.

Sauer-Danfoss serves markets such as agriculture, construction, road building, material handling, municipal, forestry, turf care, and many others.

We offer our customers optimum solutions for their needs and develop new products and systems in close cooperation and partnership with them.

Sauer-Danfoss specializes in integrating a full range of system components to provide vehicle designers with the most advanced total system design.

Sauer-Danfoss provides comprehensive worldwide service for its products through an extensive network of Global Service Partners strategically located in all parts of the world.

Local address:

Sauer-Danfoss (US) Company  
2800 East 13th Street  
Ames, IA 50010, USA  
Phone: +1 515 239-6000  
Fax: +1 515 239 6618

Sauer-Danfoss ApS  
DK-6430 Nordborg, Denmark  
Phone: +45 7488 4444  
Fax: +45 7488 4400

Sauer-Danfoss GmbH & Co. OHG  
Postfach 2460, D-24531 Neumünster  
Krokamp 35, D-24539 Neumünster, Germany  
Phone: +49 4321 871-0  
Fax: +49 4321 871 122

Sauer-Danfoss-Daikin LTD.  
Shin-Osaka TERASAKI 3rd Bldg. 6F  
1-5-28 Nishimiyahara, Yodogawa-ku  
Osaka 532-0004, Japan  
Phone: +81 6 6395 6066  
Fax: +81 6 6395 8585