

VERSIONS

Mounting flange	Shaft	Port size	European version	US version	Side port version	End port version	Flange port version	Standard shaft seal	High pressure shaft seal	Drain connection	Check valve	Specials	Main type designation
4 hole oval flange (A4-flange)	Cyl. 32 mm	G 1/2	X		X			X		Yes	Yes		OMH
	Cyl. 35 mm	G 1/2	X		X			X		Yes	Yes		OMH
	Cyl. 1 1/4 in	7/8 - 14 UNF		X	X			X		Yes	Yes		OMH
	Splined 1" SAE 6B	7/8 - 14 UNF		X	X			X		Yes	Yes		OMH
	Splined 1 1/4 in	G 1/2	X		X			X		Yes	Yes		OMH
	Splined 1 1/4 in	7/8 - 14 UNF		X	X			X		Yes	Yes		OMH
	Tapered 35 mm	G 1/2	X		X			X		Yes	Yes		OMH
Function diagram – see page : →													

Features available (options) :
Painted

CODE NUMBERS

CODE NUMBERS	DISPLACEMENT [cm ³]					Technical data – Page	Dimensions – Page
	200	250	315	400	500		
151H	1002	1003	1004	1005	1006	69	81
151H	1012	1013	1014	1015	1016	70	81
151H	1042	1043	1044	1045	1046	69	82
151H	1080	1082	1083	1084	1081	68	82
151H	1022	1023	1024	1025	1026	70	81
151H	1052	1053	1054	1055	1056	70	82
151H	-	-	1034	1035	1036	70	81
	74	74	75	75	76		

Ordering

Add the four digit prefix "151H" to the four digit numbers from the chart for complete code number.

Example:

151H1044 for an OMH 315 with A4 flange, cyl. 1 1/4 in shaft, port size 7/8 - 14 UNF.

Note: Orders will not be accepted without the four digit prefix.

TECHNICAL DATA FOR OMH WITH 1 IN SAE 6 B SPLINED SHAFT

Type		OMH	OMH	OMH	OMH	OMH	
Motor size		200	250	315	400	500	
Geometric displacement	cm ³ (in ³)	201.3 (12.32)	252.0 (15.42)	314.9 (19.27)	396.8 (24.28)	470.6 (28.80)	
Max. speed	min ⁻¹ (rpm)	cont.	370	295	235	185	155
		int. ¹⁾	445	350	285	225	190
Max. torque	Nm (lbf-in)	cont.	340 (3000)	340 (3000)	340 (3000)	340 (3000)	340 (3000)
		int. ¹⁾	510 (4500)	510 (4500)	540 (4800)	540 (4800)	540 (4600)
		peak ²⁾	640 (5650)	785 (6950)	835 (7400)	835 (7400)	835 (7400)
Max. output	kW (hp)	cont.	11.2 (15.0)	7.5 (10.0)	5.2 (7.0)	4.8 (6.5)	3.7 (5.0)
		int. ¹⁾	17.2 (23.0)	11.9 (16.0)	9.7 (13.0)	8.2 (11.0)	6.0 (8.0)
Max. pressure drop	bar (psi)	cont.	115 (1650)	90 (1300)	75 (1100)	60 (900)	50 (725)
		int. ¹⁾	170 (2500)	145 (2100)	120 (1750)	95 (1400)	75 (1100)
		peak ²⁾	225 (3300)	225 (3300)	185 (2700)	155 (2250)	160 (2300)
Max. oil flow	l/min (US gal/min)	cont.	75 (19.8)	75 (19.8)	75 (19.8)	75 (19.8)	75 (19.8)
		int. ¹⁾	90 (23.8)	90 (23.8)	90 (23.8)	90 (23.8)	90 (23.8)
Max. starting pressure with unloaded shaft	bar (psi)	7 (100)	7 (100)	7 (100)	7 (100)	7 (100)	
Min. starting torque	at max. press. drop cont.	255 (2250)	270 (2400)	280 (2500)	290 (2550)	300 (2650)	
	at max. press. drop int. ¹⁾	390 (3450)	435 (3850)	450 (4000)	450 (4000)	450 (4000)	
Min. speed ³⁾	min ⁻¹ (rpm)	10	10	8	5	5	

¹⁾ Intermittent operation: the permissible values may occur for max. 10% of every minute.

²⁾ Peak load: the permissible values may occur for max. 1% of every minute.

³⁾ Operation at lower speeds may be slightly less smooth.

TECHNICAL DATA FOR OMH WITH 32 MM AND 1 1/4 IN CYLINDRICAL SHAFT

Type			OMH	OMH	OMH	OMH	OMH
Motor size			200	250	315	400	500
Geometric displacement	cm ³ (in ³)		201.3 (12.32)	252.0 (15.42)	314.9 (19.27)	396.8 (24.28)	470.6 (28.80)
Max. speed	min ⁻¹ (rpm)	cont.	370	295	235	185	155
		int. ¹⁾	445	350	285	225	190
Max. torque	Nm (lbf-in)	cont.	510 (4510)	610 (5400)	590 (5220)	590 (5220)	580 (5130)
		int. ¹⁾	580 (5130)	700 (6200)	670 (5930)	700 (6200)	680 (6020)
		peak ²⁾	640 (5660)	790 (6990)	840 (7440)	840 (7440)	840 (7440)
Max. output	kW (hp)	cont.	16.0 (21.5)	16.0 (21.5)	12.5 (16.8)	10.0 (13.4)	8.5 (11.4)
		int. ¹⁾	18.5 (24.8)	18.5 (24.8)	14.0 (18.8)	12.0 (16.1)	10.0 (13.4)
Max. pressure drop	bar (psi)	cont.	175 (2540)	175 (2540)	135 (1960)	105 (1520)	85 (1230)
		int. ¹⁾	200 (2900)	200 (2900)	155 (2250)	125 (1810)	100 (1450)
		peak ²⁾	225 (3260)	225 (3260)	190 (2760)	155 (2250)	130 (1890)
Max. oil flow	l/min (US gal/min)	cont.	75 (19.8)	75 (19.8)	75 (19.8)	75 (19.8)	75 (19.8)
		int. ¹⁾	90 (23.8)	90 (23.8)	90 (23.8)	90 (23.8)	90 (23.8)
Max. starting pressure with unloaded shaft	bar (psi)		5 (75)	5 (75)	5 (75)	5 (75)	5 (75)
Min. starting torque	at max. press. drop	cont.	390 (3450)	520 (4600)	510 (4510)	490 (4340)	490 (4340)
	at max. press. drop	int. ¹⁾	450 (3980)	590 (5220)	590 (5220)	600 (5310)	600 (5310)
Min. speed ³⁾	min ⁻¹ (rpm)		10	10	8	5	5

¹⁾ Intermittent operation: the permissible values may occur for max. 10% of every minute.

²⁾ Peak load: the permissible values may occur for max. 1% of every minute.

³⁾ Operation at lower speeds may be slightly less smooth.

TECHNICAL DATA FOR OMH WITH 35 MM CYLINDRICAL, 1 1/4 IN SPLINED AND 35 MM TAPERED SHAFT

Type			OMH	OMH	OMH	OMH	OMH
Motor size			200	250	315	400	500
Geometric displacement	cm ³ (in ³)		201.3 (2.32)	252.0 (15.42)	314.9 (19.27)	396.8 (24.28)	470.6 (28.80)
Max. speed	min ⁻¹ (rpm)	cont.	370	295	235	185	155
		int. ¹⁾	445	350	285	225	190
Max. torque	Nm (lbf-in)	cont.	510 (4510)	610 (5400)	740 (6550)	840 (7440)	820 (7260)
		int. ¹⁾	580 (5130)	700 (6200)	820 (7260)	980 (8670)	1040 (9210)
		peak ²⁾	640 (5660)	790 (6990)	980 (8670)	1090 (9650)	1170 (10360)
Max. output	kW (hp)	cont.	16.0 (21.5)	16.0 (21.5)	14.0 (18.8)	12.5 (16.8)	11.0 (14.8)
		int. ¹⁾	18.5 (24.8)	18.5 (24.8)	15.5 (20.8)	15.0 (20.1)	14.0 (18.8)
Max. pressure drop	bar (psi)	cont.	175 (2540)	175 (2540)	175 (2540)	155 (2250)	125 (1810)
		int. ¹⁾	200 (2900)	200 (2900)	200 (2900)	190 (2760)	160 (2320)
		peak ²⁾	225 (3260)	225 (3260)	225 (3260)	210 (3050)	180 (2610)
Max. oil flow	l/min (US gal/min)	cont.	75 (19.8)	75 (19.8)	75 (19.8)	75 (19.8)	75 (19.8)
		int. ¹⁾	90 (23.8)	90 (23.8)	90 (23.8)	90 (23.8)	90 (23.8)
Max. starting pressure with unloaded shaft	bar (psi)		5 (75)	5 (75)	5 (75)	5 (75)	5 (75)
Min. starting torque	at max. press. drop	cont.	390 (3450)	520 (4600)	660 (5840)	720 (6370)	720 (6370)
		int. ¹⁾	450 (3980)	590 (5220)	730 (6460)	880 (7790)	880 (7790)
Min. speed ³⁾	min ⁻¹ (rpm)		10	10	8	5	5

Type			Max. inlet pressure	Max. return pressure with drain line
OMH 200 - 500	bar (psi)	cont.	200 (2900)	175 (2540)
	bar (psi)	int. ¹⁾	225 (3260)	200 (2900)
	bar (psi)	peak ²⁾	250 (3630)	225 (3260)

¹⁾ Intermittent operation: the permissible values may occur for max. 10% of every minute.

²⁾ Peak load: the permissible values may occur for max. 1% of every minute.

³⁾ Operation at lower speeds may be slightly less smooth.

**MAX. PERMISSIBLE
SHAFT SEAL PRESSURE**

OMH with standard shaft seal, check valves and without use of drain connection:
The pressure on the shaft seal never exceeds the pressure in the return line

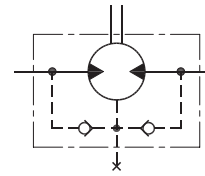

OMH with standard shaft seal, check valves and with drain connection:
The shaft seal pressure equals the pressure on the drain line.

151-320.10

Max. return pressure without drain line or max. pressure in the drain line

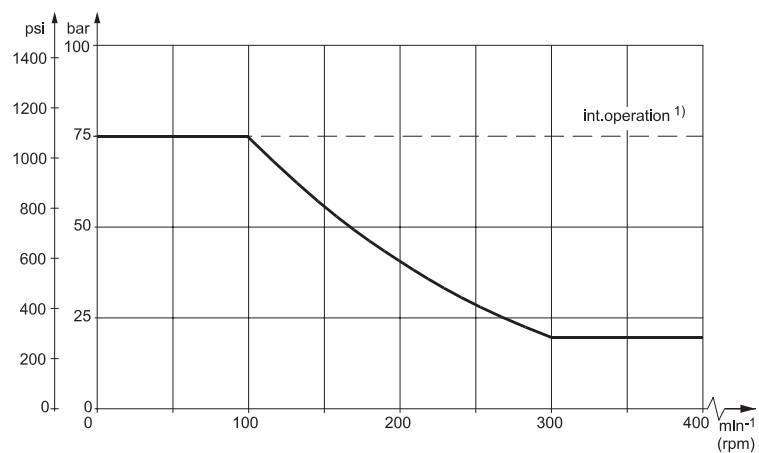

151-1565.10

¹⁾ Intermittent operation: the permissible values may occur for max. 10% of every minute.

PRESSURE DROP IN MOTOR

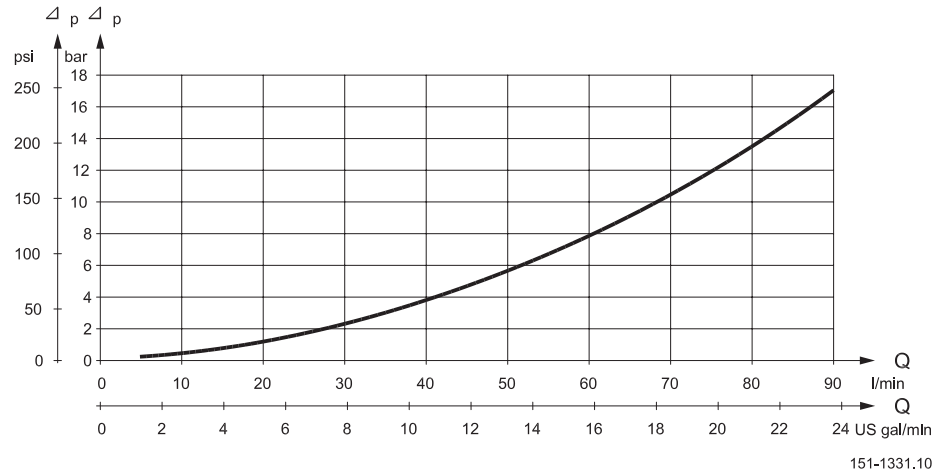

151-1331.10

The curve applies to an unloaded motor shaft and an oil viscosity of 35 mm²/s (165 SUS)

OIL FLOW IN DRAIN LINE

The table shows the max. oil flow in the drain line at a return pressure less than 5-10 bar (75-150 psi).

Pressure drop bar (psi)	Viscosity mm ² /s (SUS)	Oil flow in drain line l/min (US gal/min)
100 (1450)	20 (100)	2.5 (0.66)
	35 (165)	1.8 (0.78)
140 (2030)	20 (100)	3.5 (0.93)
	35 (165)	2.8 (0.74)

DIRECTION OF SHAFT ROTATION

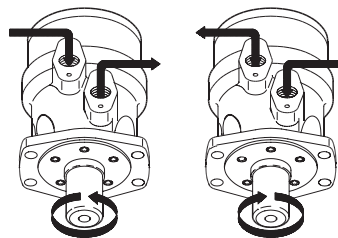

151-1839.10

**PERMISSIBLE SHAFT
LOADS FOR OMH**

The permissible shaft load (P_{rad}) is calculated from the speed (n) and the distance (l) between the point of load application and the mounting flange.

$$P_{rad} = \frac{1100}{n} \times \frac{250000}{103.5 + l} \text{ N}^*; l \text{ in mm}$$

$$P_{rad} = \frac{1100}{n} \times \frac{2215}{4.07 + l} \text{ lbf}^*; l \text{ in inch}$$

* $n > 200 \text{ min}^{-1} \text{ (rpm)}$; $l < 60 \text{ mm (2.36 in)}$
 $n < 200 \text{ min}^{-1} \text{ (rpm)}$; $\Rightarrow P_{rmax} = 11000 \text{ N (2475 lbf)}$

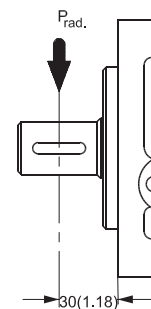
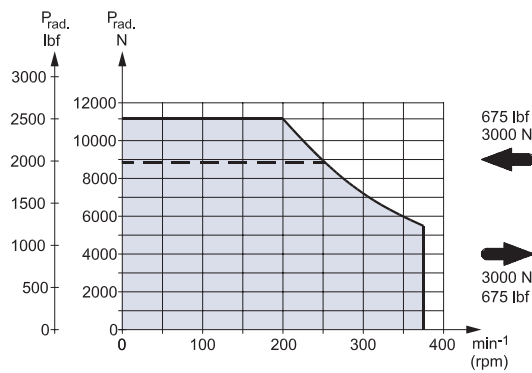

151-1474.10

----- 1 in SAE 6B splined shaft

The drawing shows the permissible radial load when $l = 30 \text{ mm (1.18 in)}$.

FUNCTION DIAGRAMS

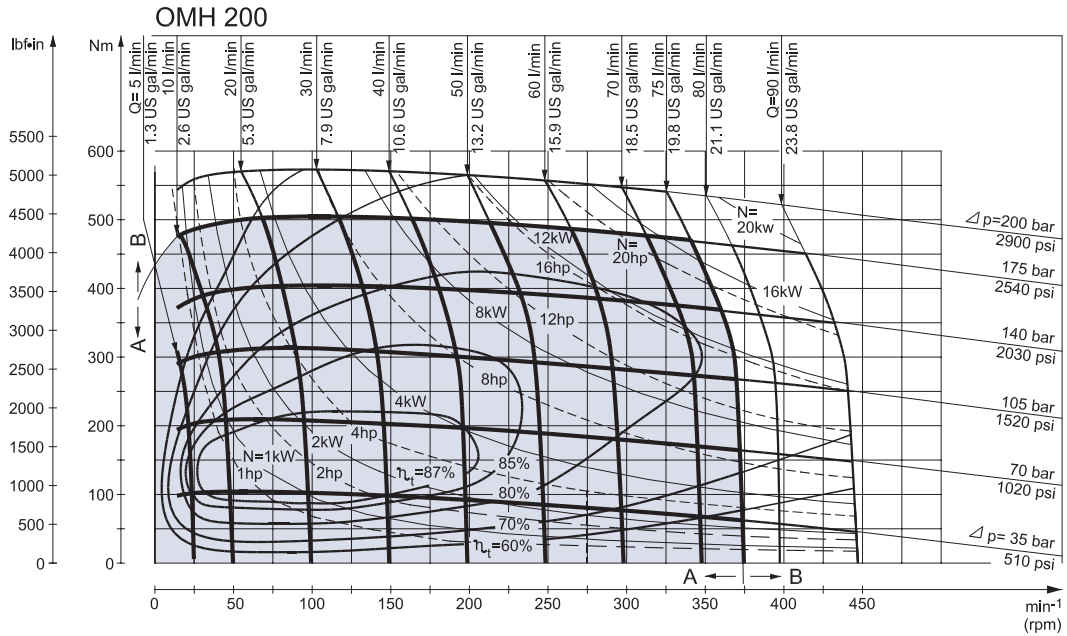

151-1486.10

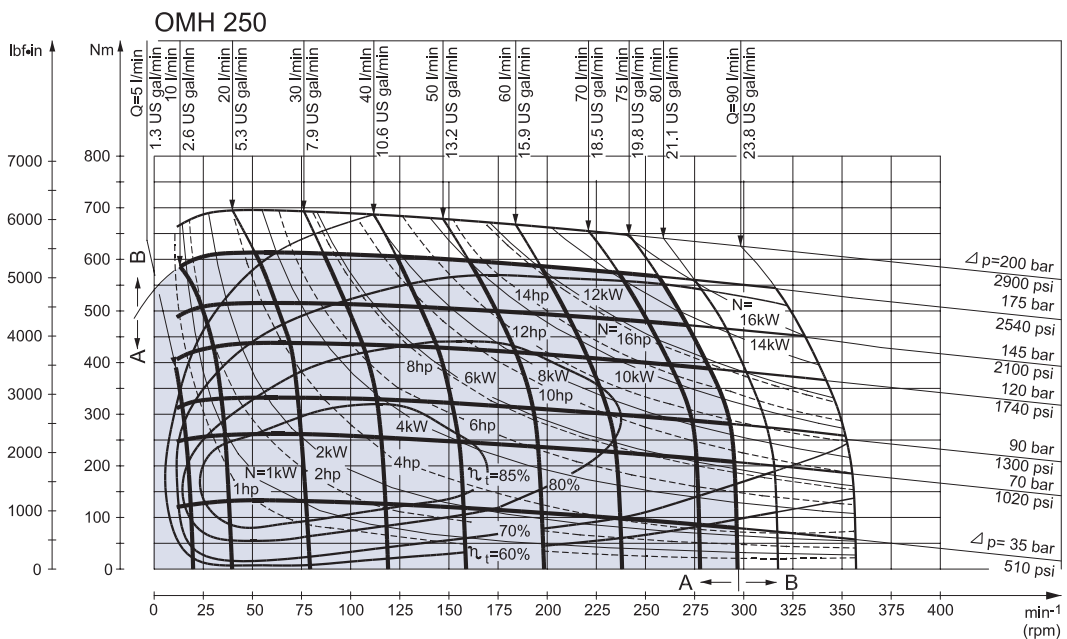

151-1487.10

Explanation of function diagram use, basis and conditions can be found on page 7.

- A: Continuous range
- B: Intermittent range (max. 10% operation every minute)

Max. permissible continuous/intermittent pressure drop for the actual shaft version can be found on page 68-70.

Note: Intermittent pressure drop and oil flow must not occur simultaneously.

FUNCTION DIAGRAMS

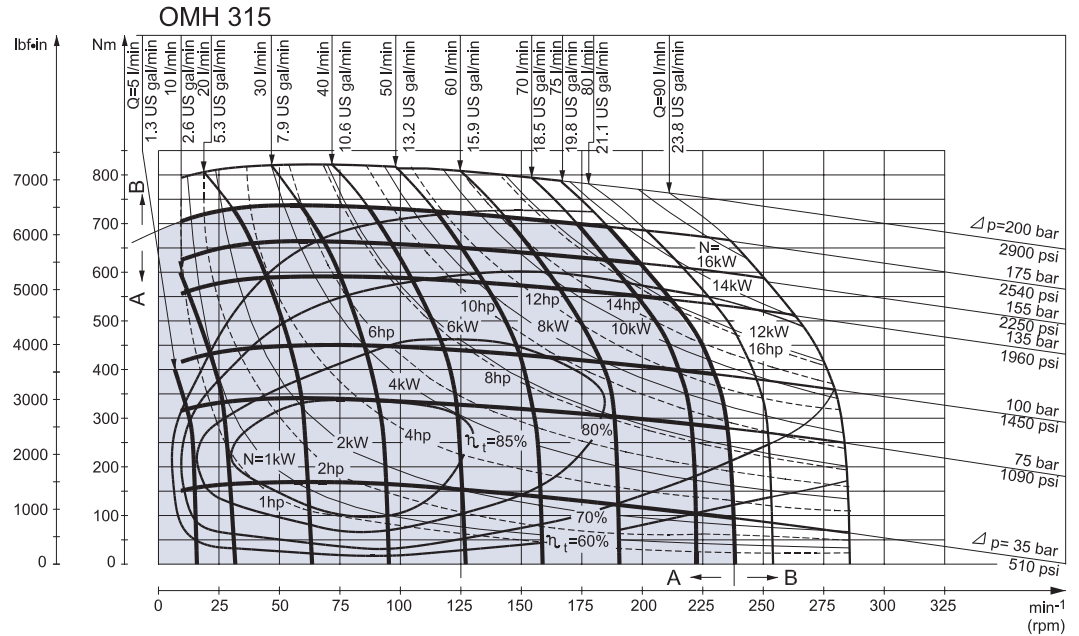

151-1488.10

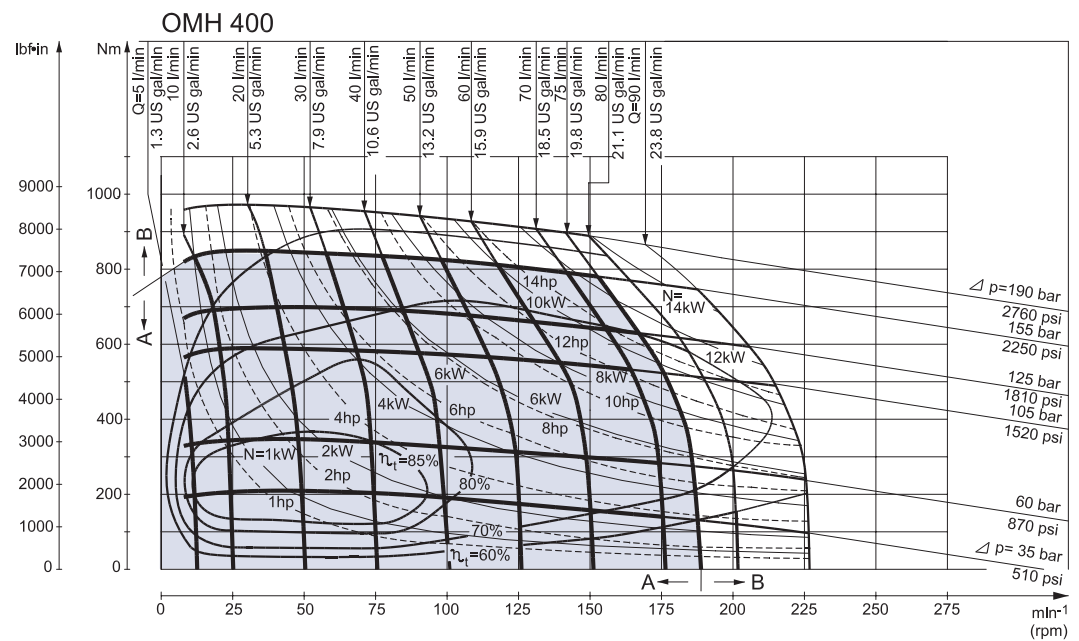

151-1489.10

Explanation of function diagram use, basis and conditions can be found on page 7.

- A: Continuous range
- B: Intermittent range (max. 10% operation every minute)

Max. permissible continuous/intermittent pressure drop for the actual shaft version can be found on page 68-70.

Note: Intermittent pressure drop and oil flow must not occur simultaneously.

FUNCTION DIAGRAMS

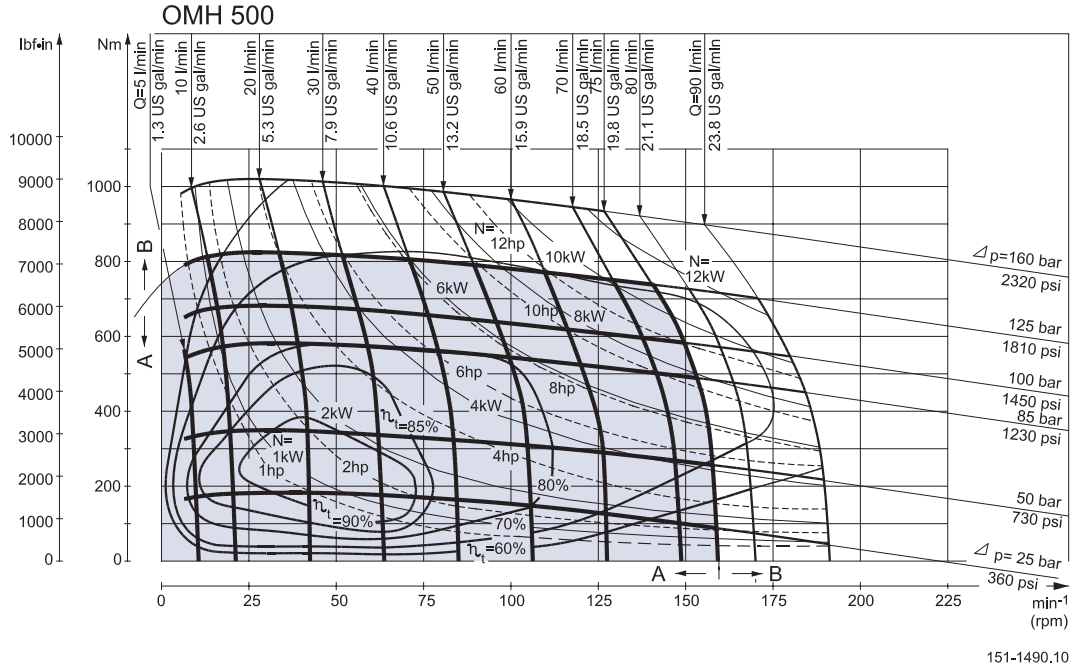

Explanation of function diagram use, basis and conditions can be found on page 7.

- A: Continuous range
- B: Intermittent range (max. 10% operation every minute)

Max. permissible continuous/intermittent pressure drop for the actual shaft version can be found on page 68-70.

Note: Intermittent pressure drop and oil flow must not occur simultaneously.

SHAFT VERSION

- A: Cylindrical shaft
32 mm
- D: Parallel key
A10 × 8 × 45
DIN 6885

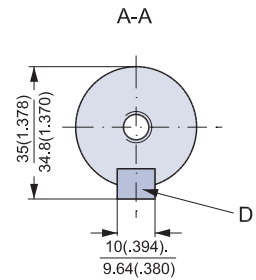
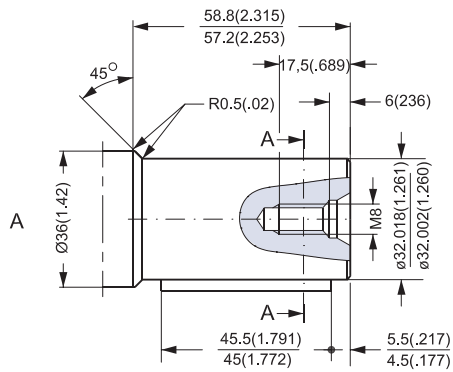

- B: Cylindrical shaft
35 mm
- E: Parallel key
A10 × 8 × 45
DIN 6885

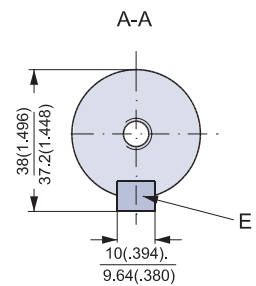
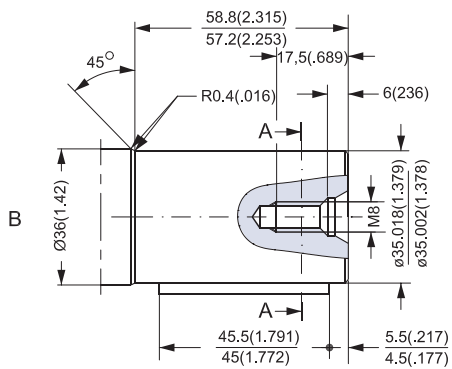

- US version**
- C: Cylindrical shaft
1 1/4 in
- F: Parallel key
5/16 × 5/16 × 1 1/4 in
SAE J 744

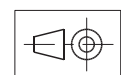
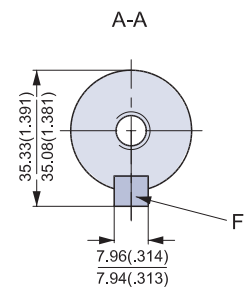
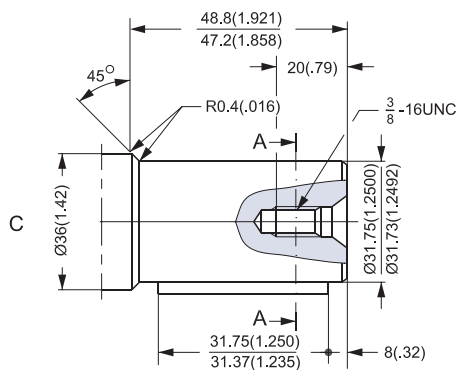

151-1852.10

SHAFT VERSION

D: Splined shaft
SAE 6 B (B.S. 2059)
Straight-sided,
bottom fitting, deep.
Fit 2
Nom. size 1 in

*Deviates from
SAE 6 B (B.S. 2059)

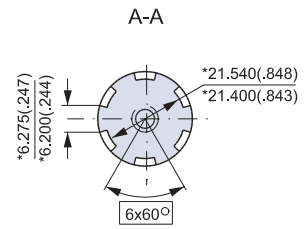
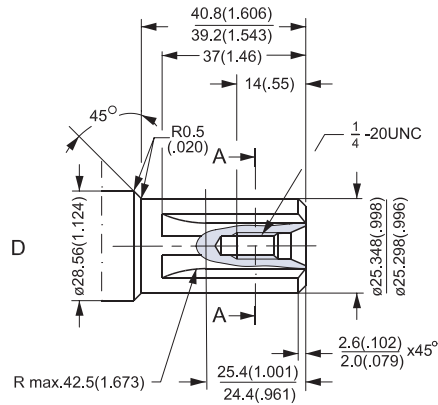

E: Involute splined shaft
ANS B92.1 - 1980 standard
Flat root side fit
Pitch 12/24
Teeth 14
Major dia. 1.25 in
Pressure angle 30°

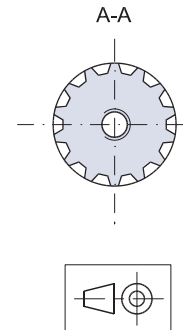
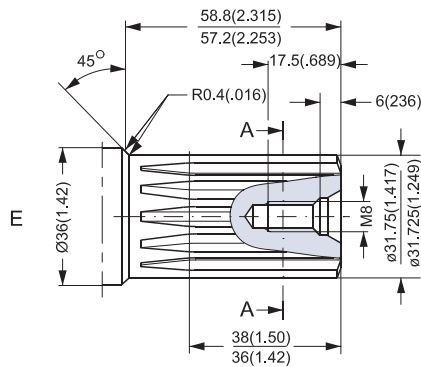

151-1853.10

SHAFT VERSION

US version

- F. Involute splined shaft
- ANS B92.1 - 1970 standard
- Flat root side fit
- Pitch 12/24
- Teeth 14
- Major dia. 1.25 in
- Pressure angle 30°

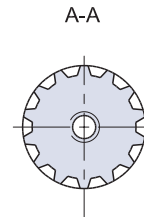
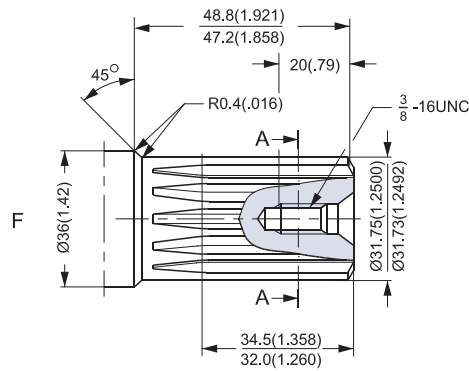

- G: Tapered shaft 35 mm (ISO/R775)
- I: DIN 937 NV 410
- Tightening torque: 200 ± 10 Nm (1770 ± 85 lbf.in)
- H: Taper 1:10
- L: Parallel key B6 × 6 × 20 DIN 6885

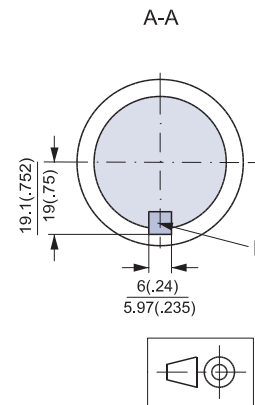
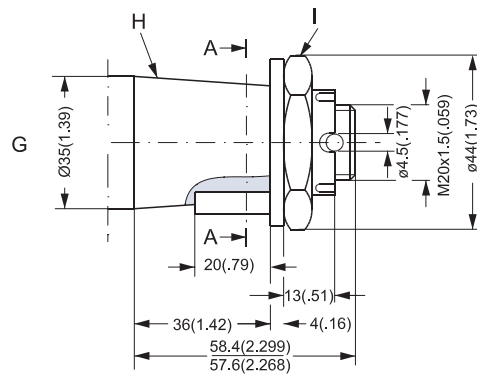

151-1854.10

PORT THREAD VERSIONS

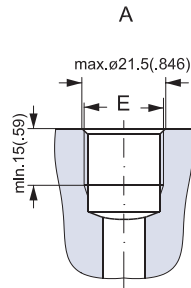

A: G main ports
E: ISO 228/1 - G^{1/2}

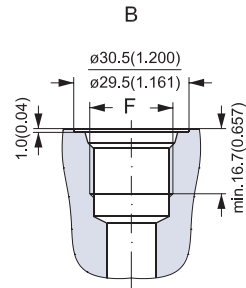

B: UNF main ports
F: ⁷/₈ - 14 UNF
O-ring boss port

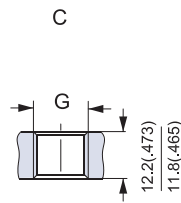

C: G drain port
G: ISO 228/1 - G^{1/4}

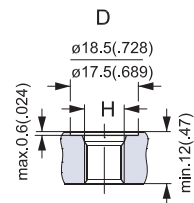

D: UNF drain port
H: ⁷/₁₆ - 20 UNF
O-ring boss port

151-1858.10

DIMENSIONS

Side port version with 4 hole oval mounting flange (A4-flange).

Type	L mm (in)	L ₁ mm (in)
OMH 200	170.1 (6.70)	27.8 (1.09)
OMH 250	177.1 (6.97)	34.8 (1.37)
OMH 315	185.8 (7.31)	43.5 (1.71)
OMH 400	197.1 (7.76)	54.8 (2.16)
OMH 500	207.3 (8.16)	65.0 (2.56)

C: Drain connection
G 1/4; 12 mm (0.47 in) deep
D: G 1/2; 15 mm (0.59 in) deep

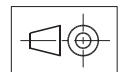
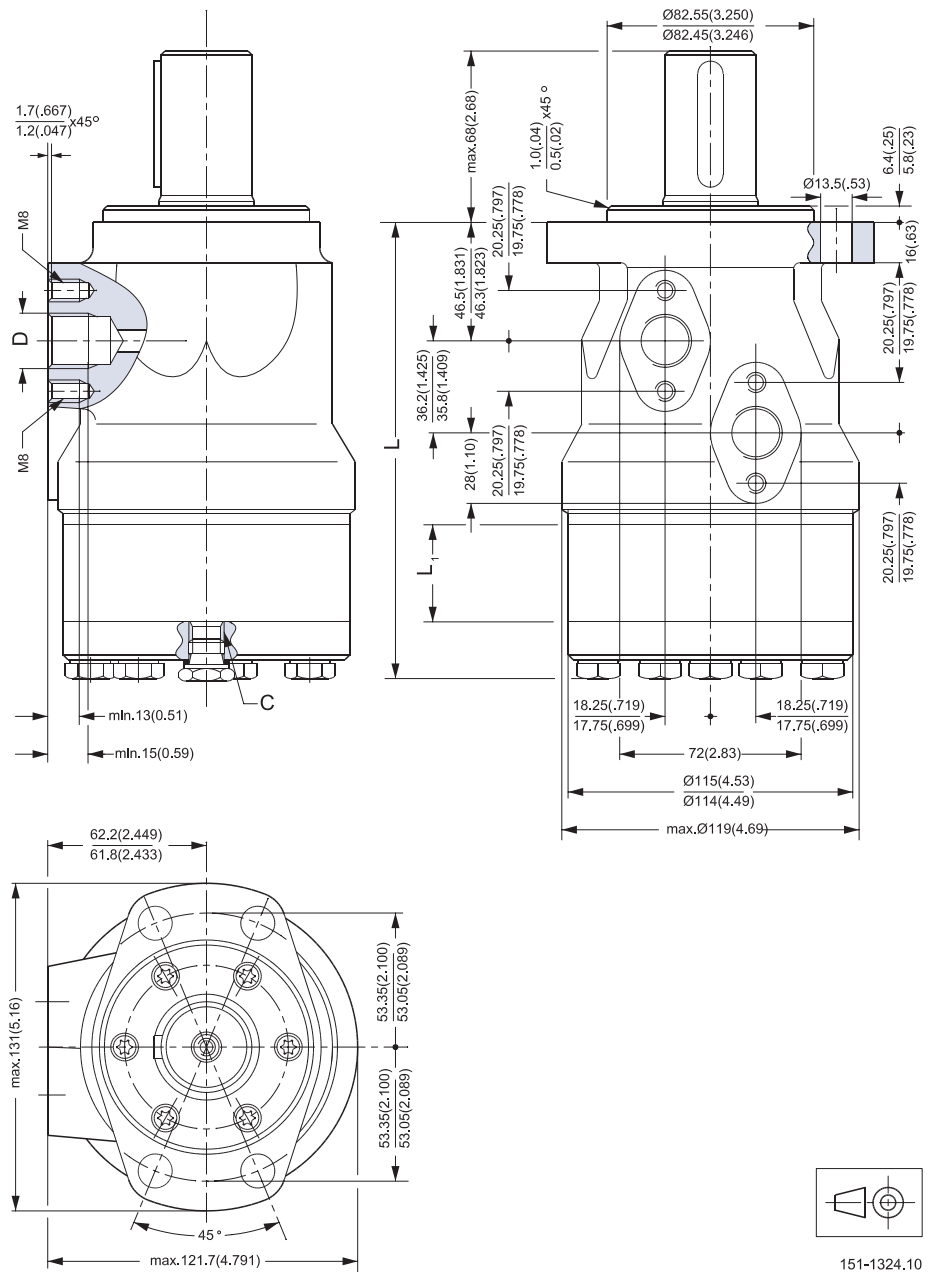

151-1324.10

DIMENSIONS

Side port version with 4 hole oval mounting flange (A4 flange).

Output shaft max.	L ₂ mm (in)
Splined shaft 1 in	50.5 (1.99)
Other shaft versions	58.0 (2.28)

Type	L mm (in)	L ₁ mm (in)
OMH 200	170.1 (6.70)	27.8 (1.09)
OMH 250	177.1 (6.97)	34.8 (1.37)
OMH 315	185.8 (7.31)	43.5 (1.71)
OMH 400	197.1 (7.76)	54.8 (2.16)
OMH 500	207.3 (8.16)	65.0 (2.56)

- C: Drain connection
 $\frac{7}{16}$ - 20 UNF;
 12 mm (0.47 in) deep
 D: $\frac{7}{8}$ - 14 UNF;
 15 mm (0.59 in) deep

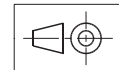
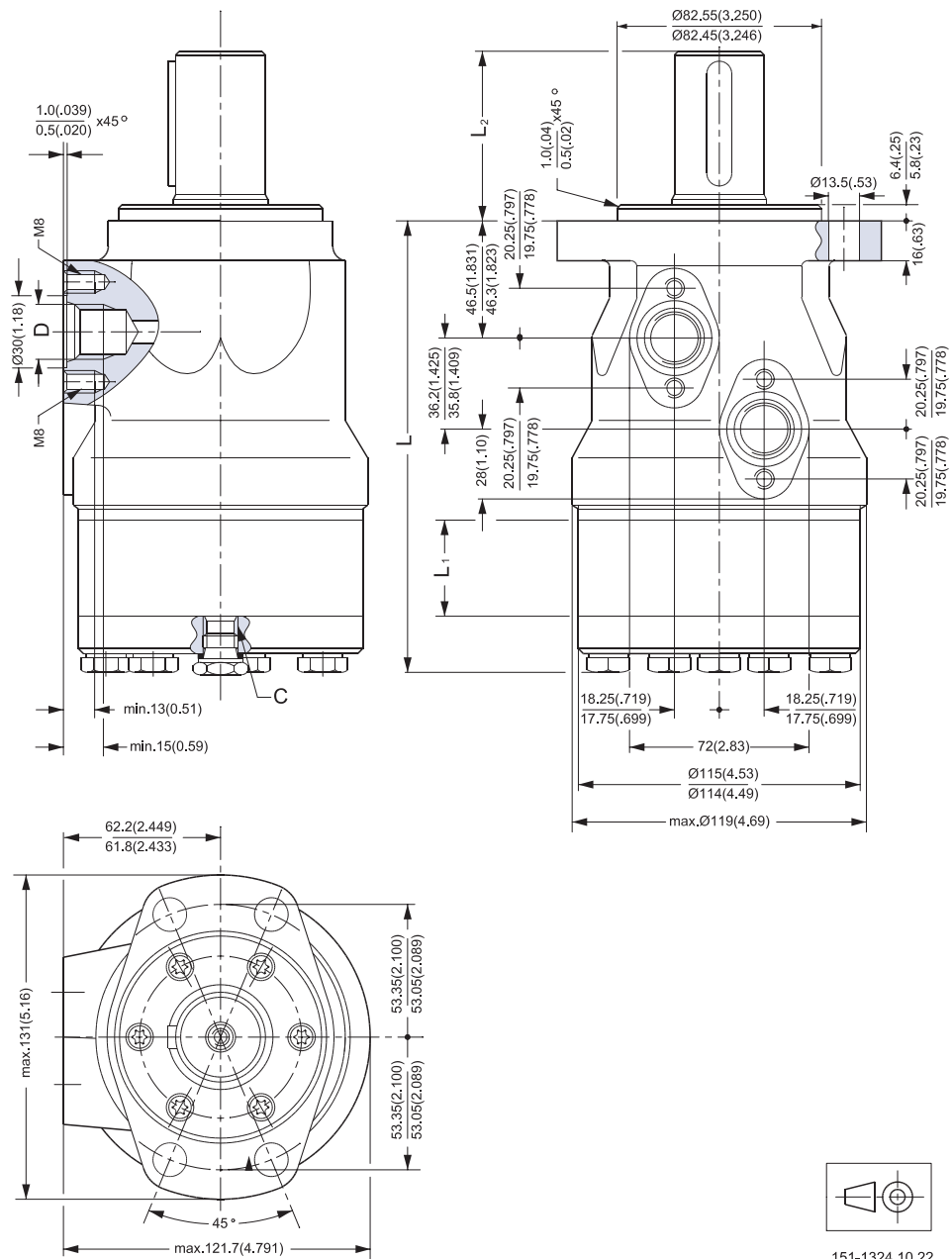

151-1324.10.22

